

Series DCS-RW



Two-shell railroad and track grabs

DC-RB

Excavator weight class (t): 13-20

Load bearing capacity (t): Grab: 4 / Slewing gear: 10

Operating pressure (bar): 320 grabbing / 140 slewing

Bulk weight up to (t/m³): 3

Closing force max. (kN): 42

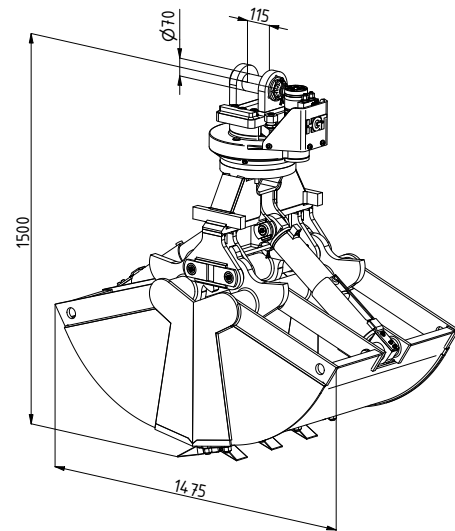
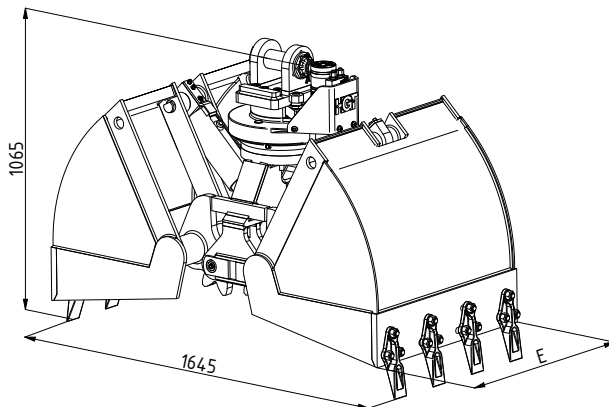

Type	Capacity - SAE (l)	Weight (kg)	Cutting width E (mm)	Number of teeth
DC-RB-600	350	700	620	5
DC-RB-700	400	730	700	7
DC-RB-800	450	760	800	7
DC-RB-900	500	790	900	9
DC-RB-1000	550	820	1000	9

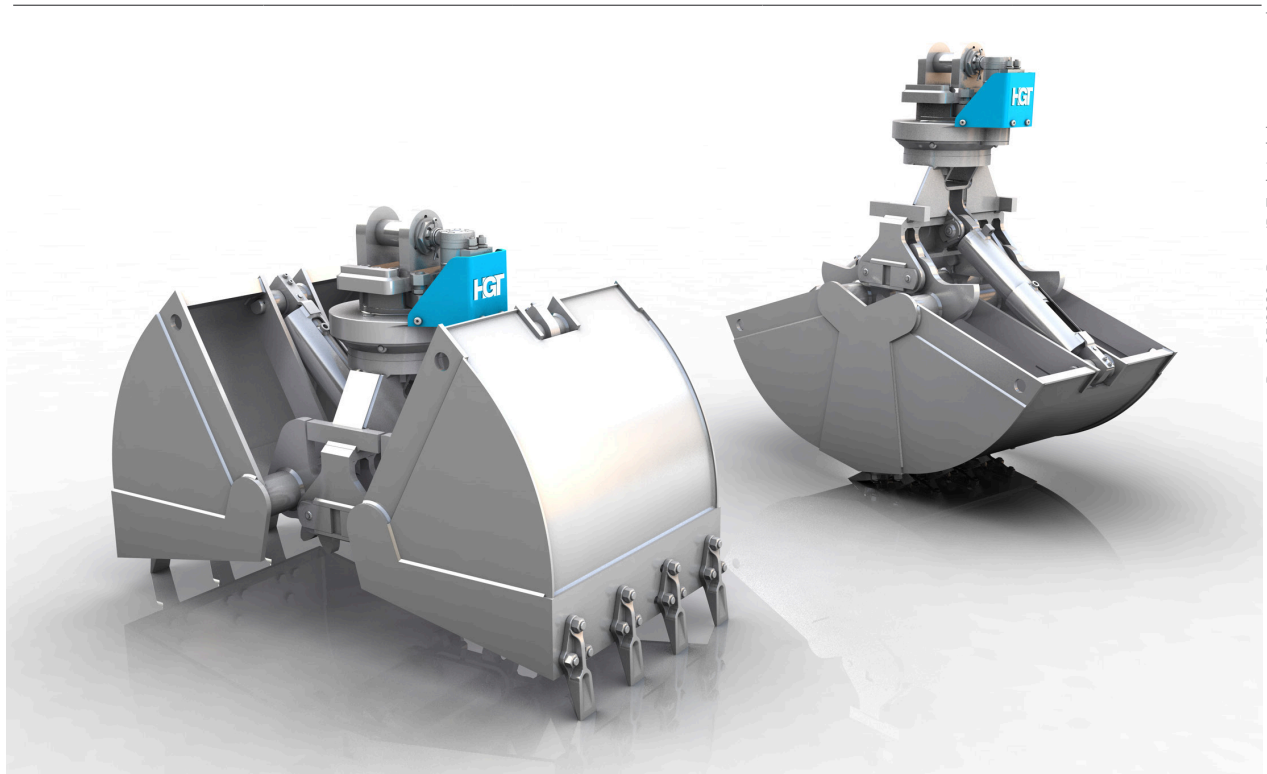

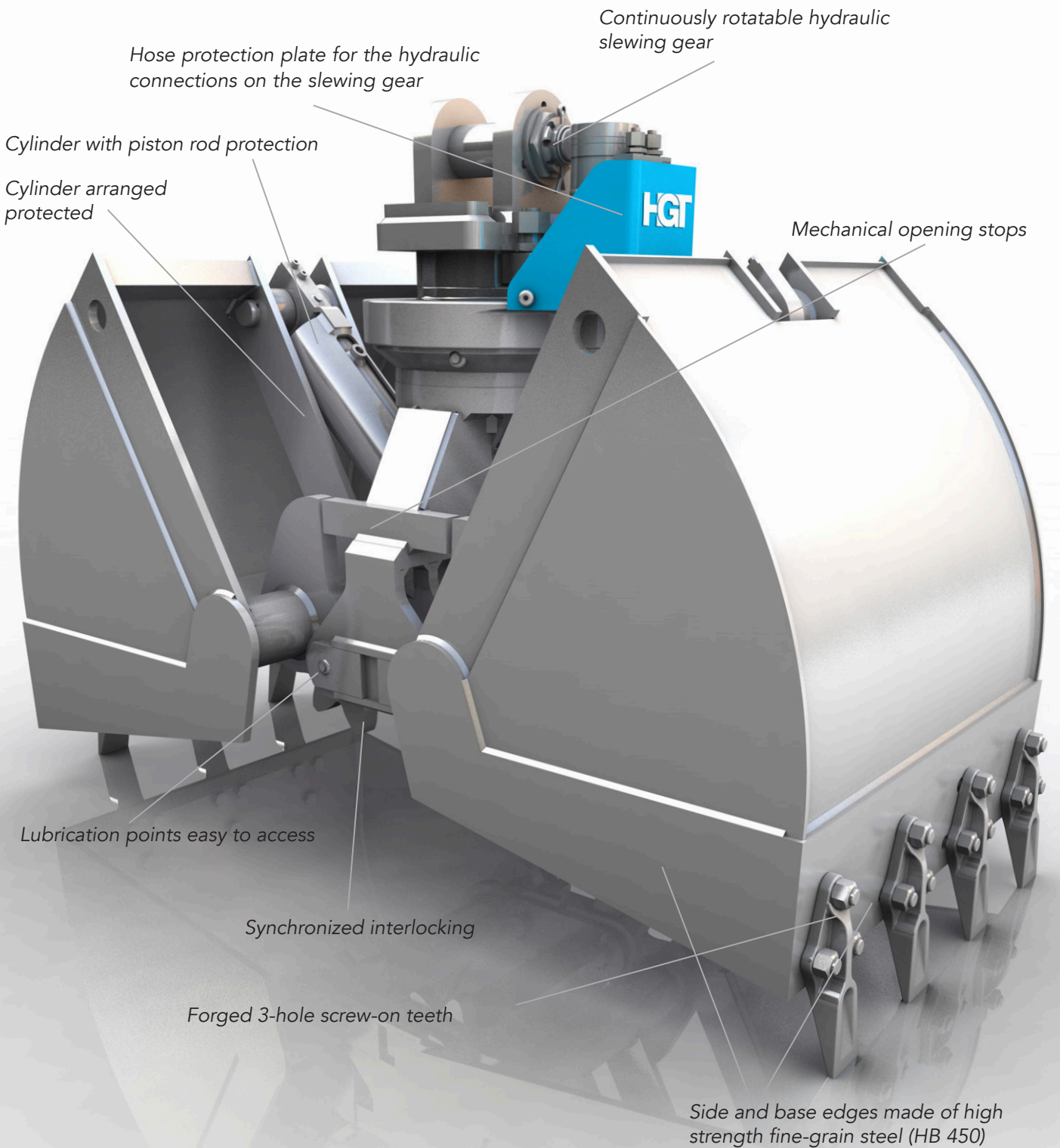

The special series for railroad and track construction, optimized for use on 2-way mobile excavators. Low installation height, adapted opening width, with max. closing forces.