

Series DCS-RT



Two-shell grab tilt rotator

# DCS-RT-3

Excavator weight class (t): 9-15  
 Grab carrying capacity (t): 3  
 Operating pressure (bar): 350

Bulk weight up to (t/m<sup>3</sup>): 2  
 Closing force max. (kN): 49

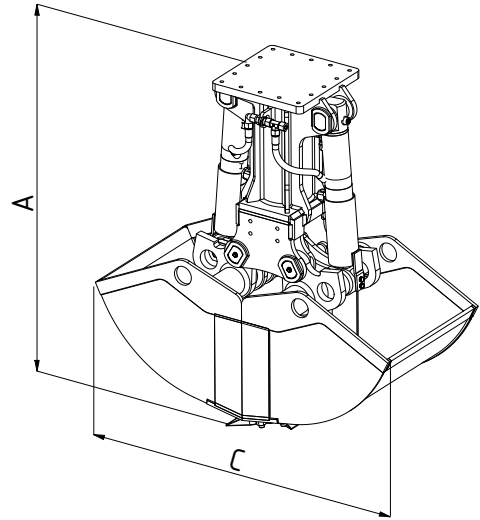
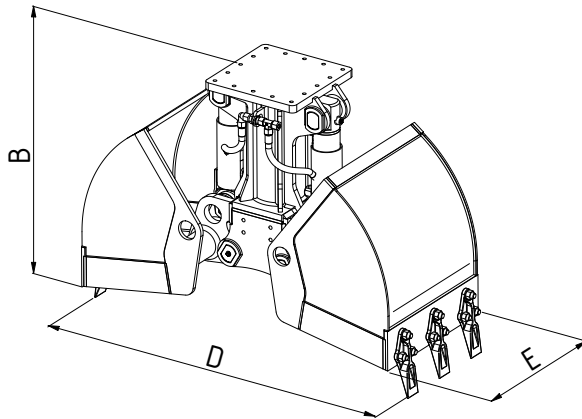

Type	Capacity - SAE (l)	Number of teeth	Weight (kg)	Dimensions (mm)				
				A	B	C	D	E
DCS-RT-3-400	140	5	470	1357	1034	1300	1355	400
DCS-RT-3-500	180	5	499	1357	1034	1300	1355	500
DCS-RT-3-600	220	5	524	1357	1034	1300	1355	600
DCS-RT-3-700	260	5	546	1357	1034	1300	1355	700
DCS-RT-3-800	300	5	573	1357	1034	1300	1355	800

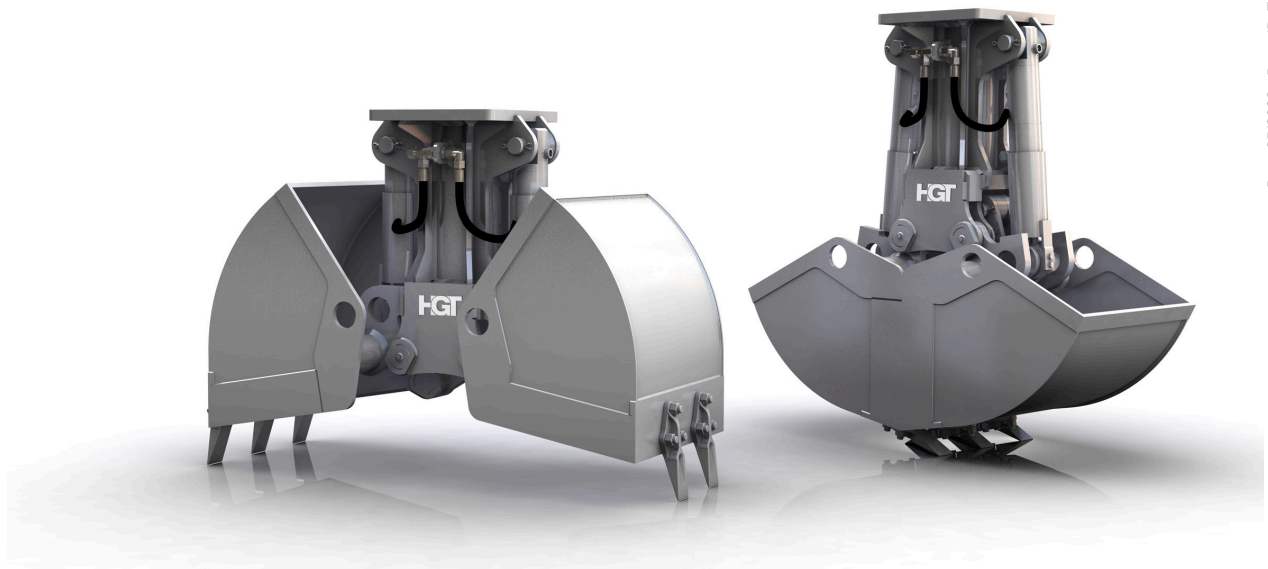

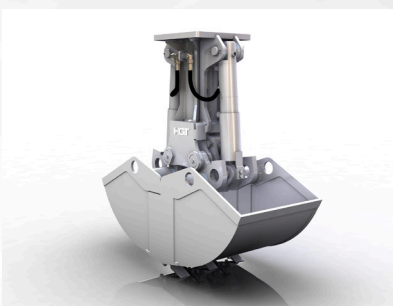
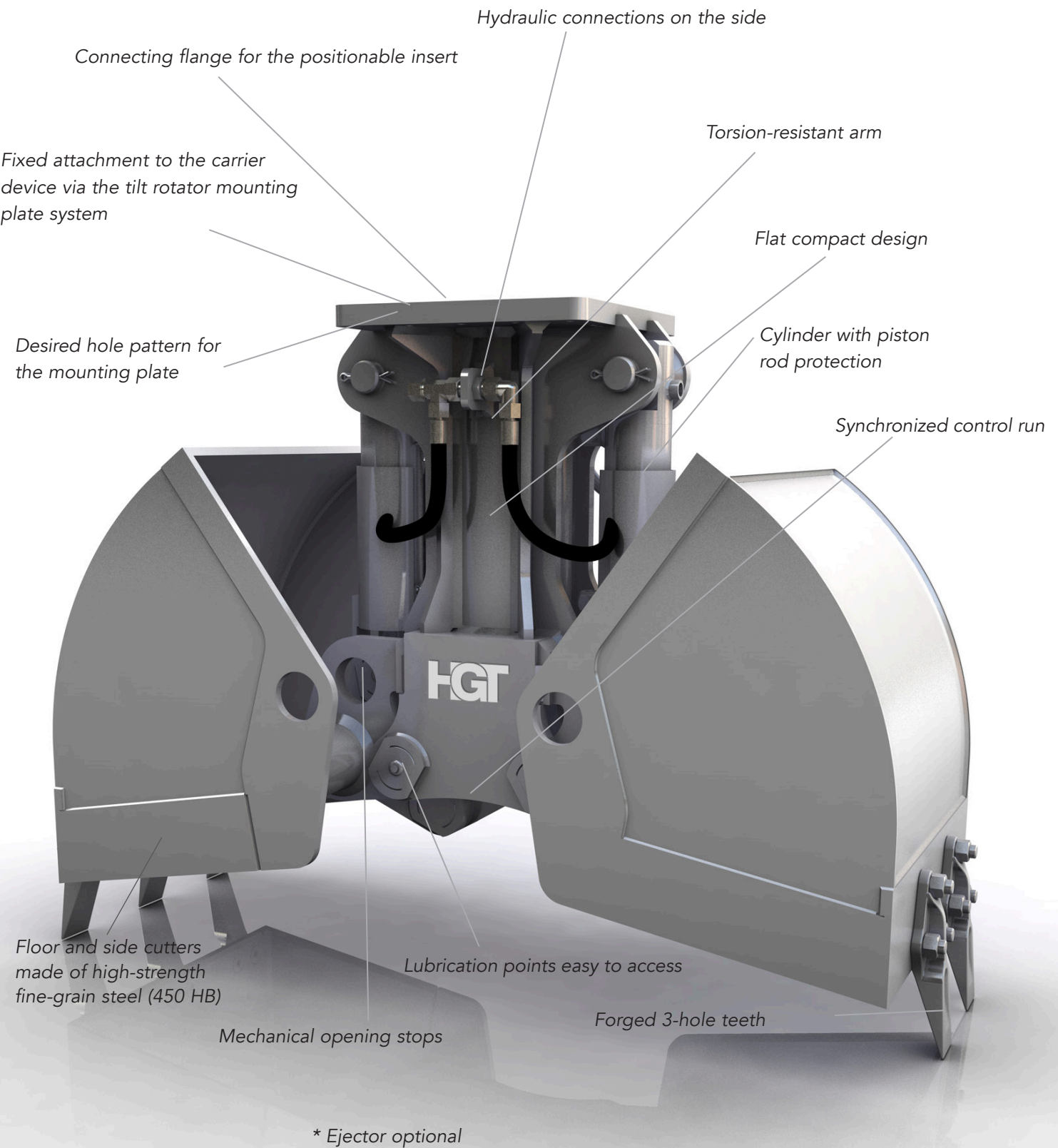

Multi-use grab for a wide range of applications for handling different materials such as demolition, sorting scrap, loading and sorting and recycled materials.