

Series DG



## Two-shell demolition grabs

# DG02

Excavator weight class (t): 1  
Capacity (l): 15

Operating pressure (bar): 320 grabbing / 320 slewing  
Clamping force (kN): 11

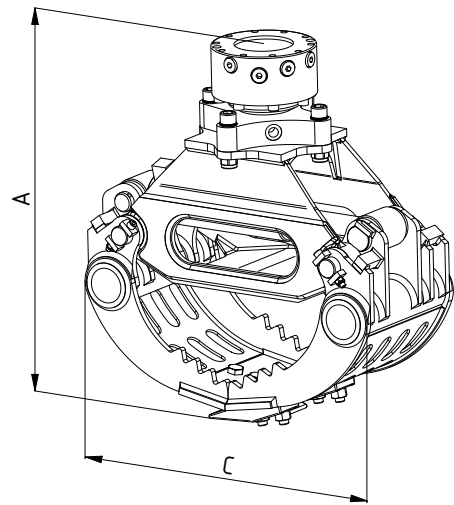
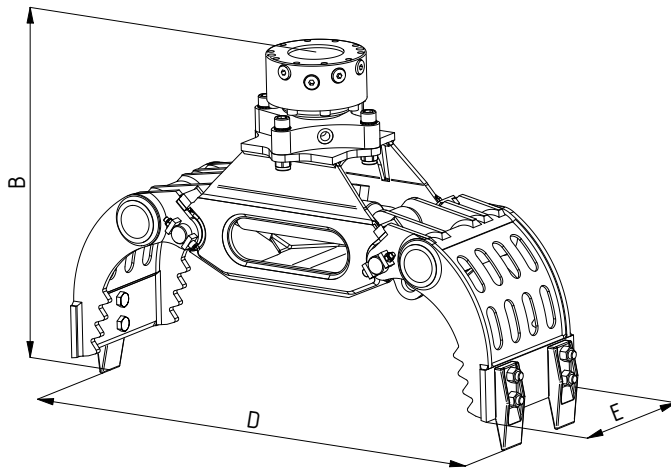

Type	Max. grabber load bearing capacity (t)	Load bearing capacity rotary motor max. (t)	Weight without adaptor plate (kg)	Dimensions (mm)				
				A	B	C	D	E
DG02	0.5	1.8	75	570	580	516	850	250





Continuously rotatable hydraulic slewing gear

Connections at the front

Mechanical opening stops

Flat, compact design - Grab hydraulic lines and synchronized control run protected in the arm

Lubrication points easy to access

Shells made of high-strength fine-grain steel (450 HB)

Jagged side parts for improved grip

Forged 2-hole screw-on teeth

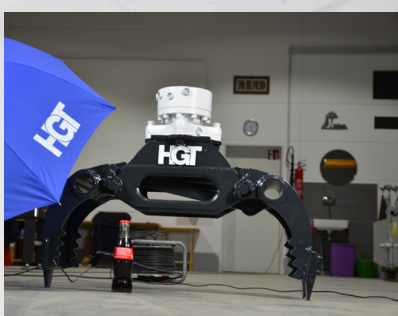

Multi-use grab for a wide range of set of handling different materials such as demolition, sorting scrap, loading and sorting and recycled materials.