

Series DG



## Two-shell demolition grabs

# DG05

Excavator weight class (t): 1-2  
Capacity (l): 45

Operating pressure (bar): 250 grabbing / 250 slewing  
Clamping force (kN): 13

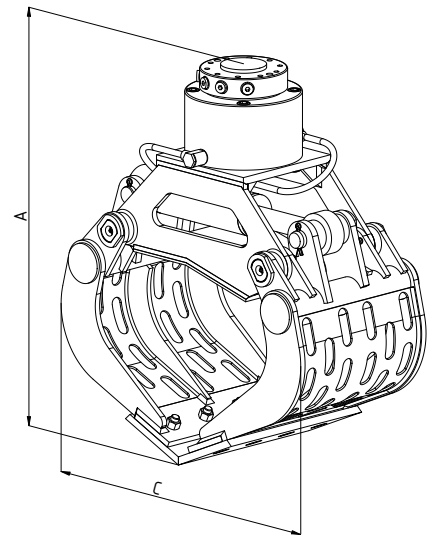
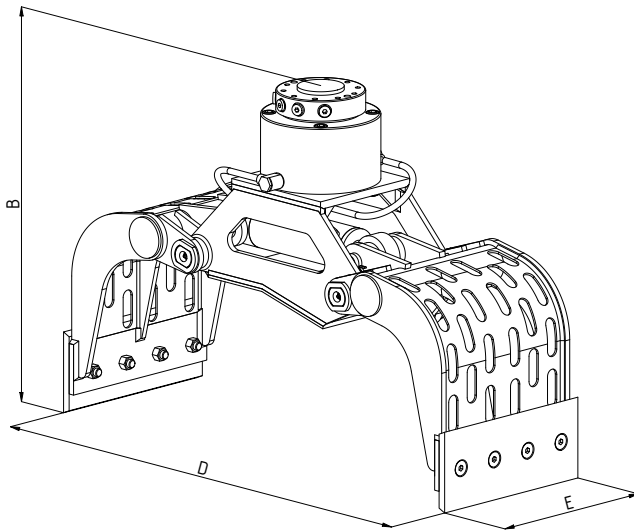

Type	Max.grabber load bearing capacity (t)	Load bearing capacity slewing gear max. (t)	Weight without adaptor plate (kg)	Dimensions (mm)				
				A	B	C	D	E
DG05	1	5	160	770	710	660	1030	360



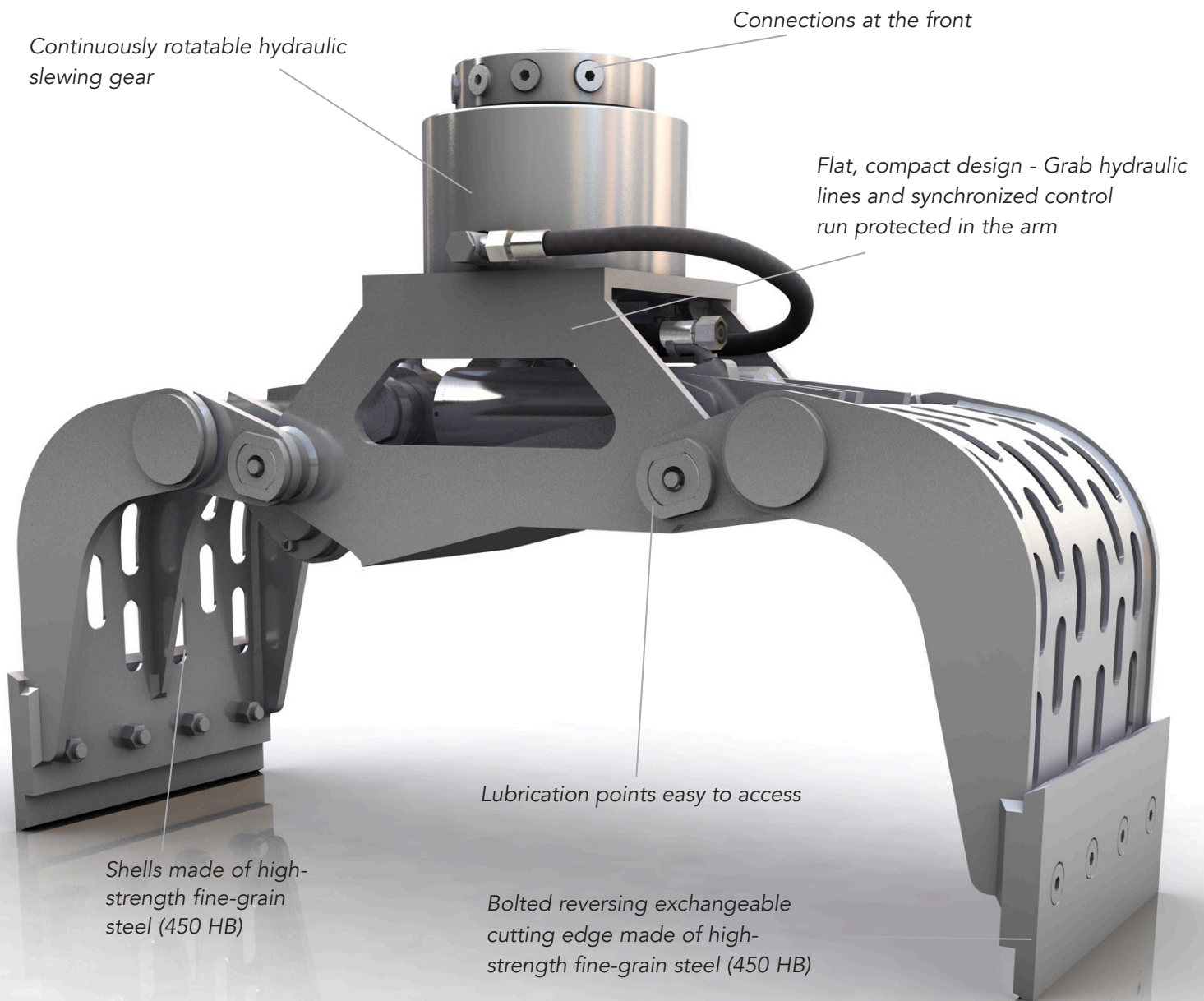

Multi-use grab for a wide range of set of handling different materials such as demolition, sorting scrap, loading and sorting and recycled materials.