

Series DG



Two-shell demolition grabs

DG2

Excavator weight class (t): 5-9
Capacity (l): 200

Operating pressure (bar): 300 grabbing / 250 slewing
Clamping force (kN): 36

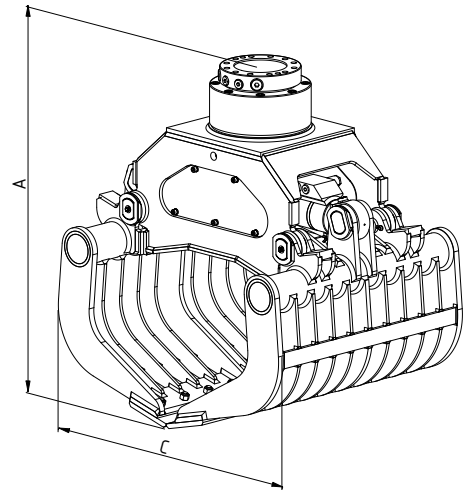
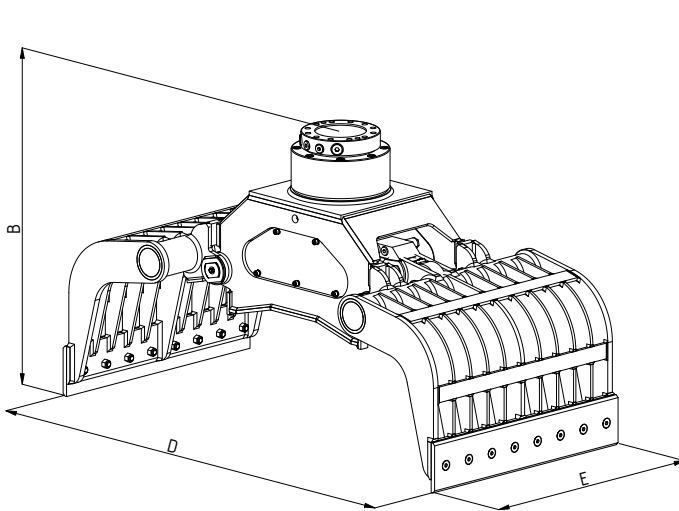

Type	Max. grabber load bearing capacity (t)	Load bearing capacity slewing gear max. (t)	Weight without adaptor plate (kg)	Dimensions (mm)				
				A	B	C	D	E
DG2	2	10	508	1080	950	940	1620	600

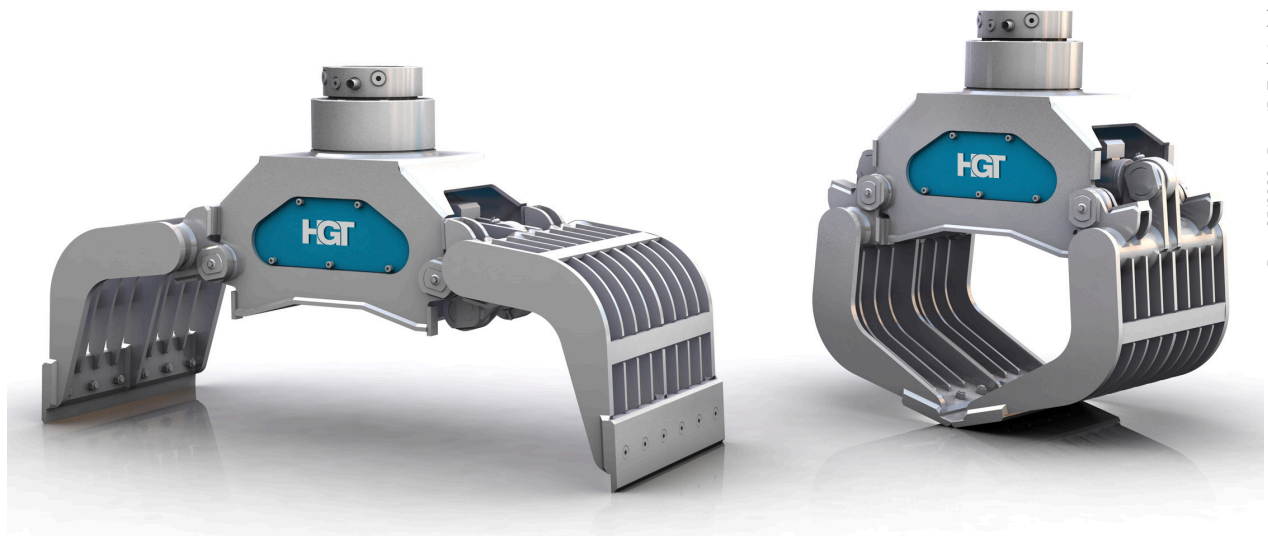

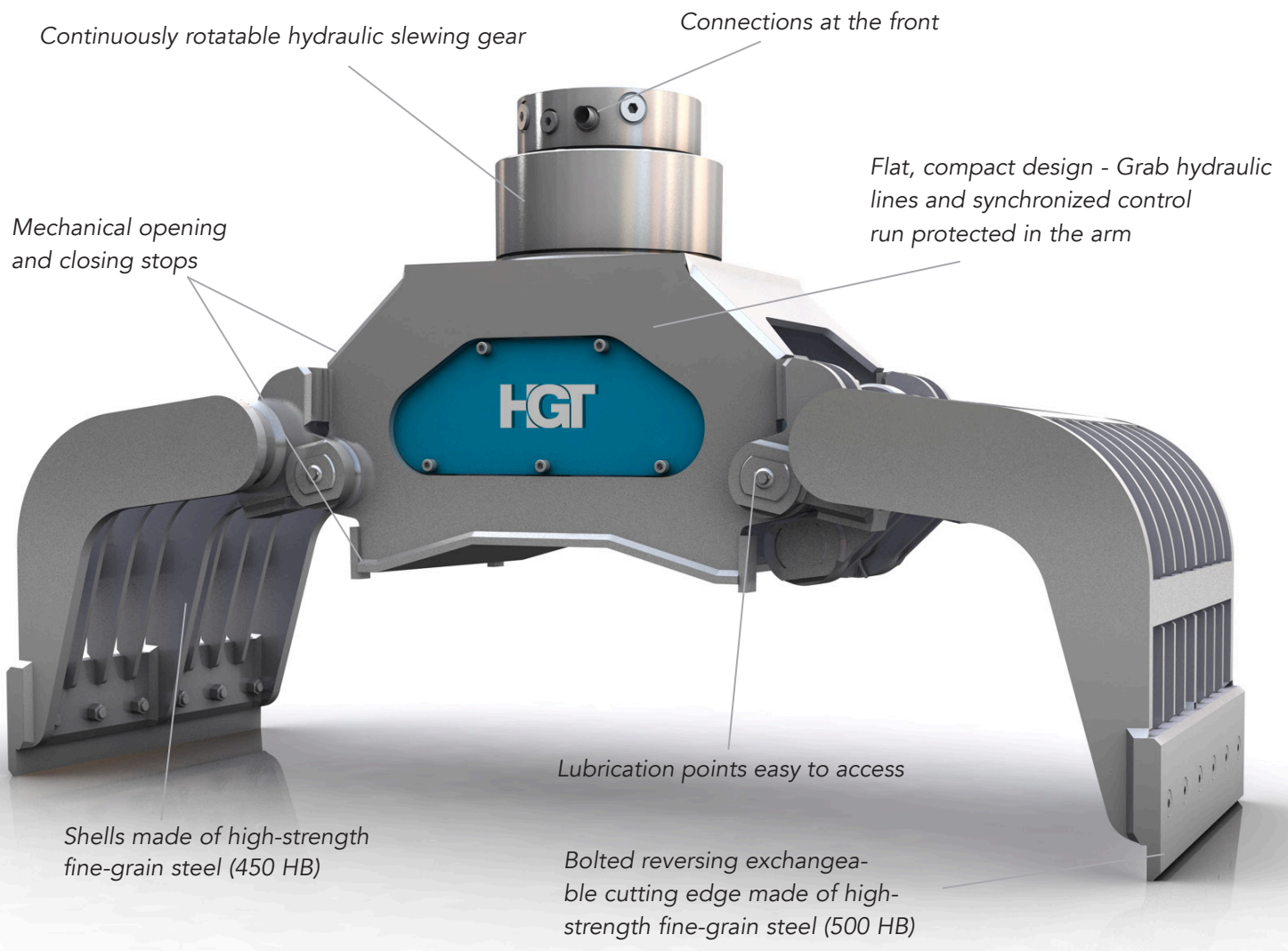

Multi-use grab for a wide range of set of handling different materials such as demolition, sorting scrap, loading and sorting and recycled materials.