

Series DG



Two-shell demolition grabs

DG3.3

Excavator weight class (t): 9-15
Capacity (l): 400

Operating pressure (bar): 350 grabbing / 250 slewing
Clamping force (kN): 50

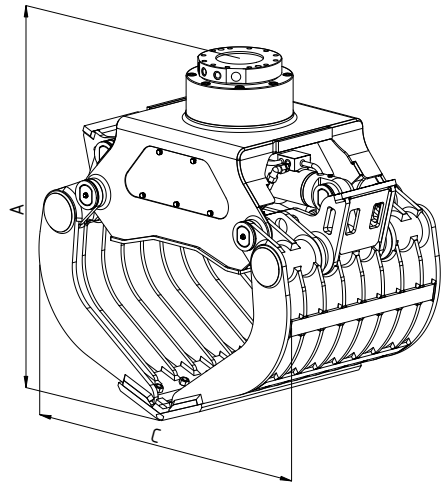
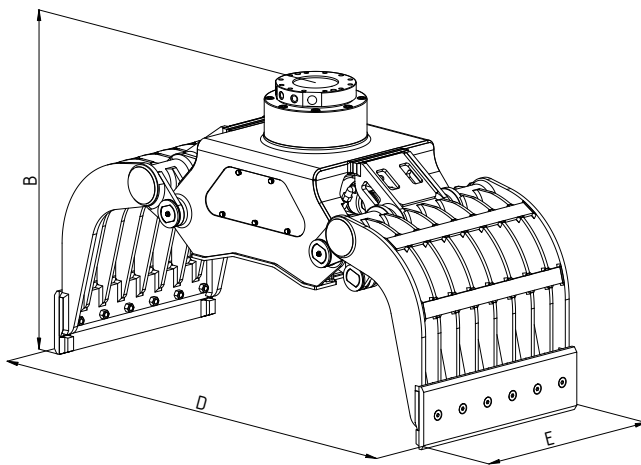

Type	Max. grabber load bearing capacity (t)	Load bearing capacity rotary motor max. (t)	Weight without adaptor plate (kg)	Dimensions (mm)				
				A	B	C	D	E
DG3.3-800-R	4	15	942	1258	1293	1200	1930	800



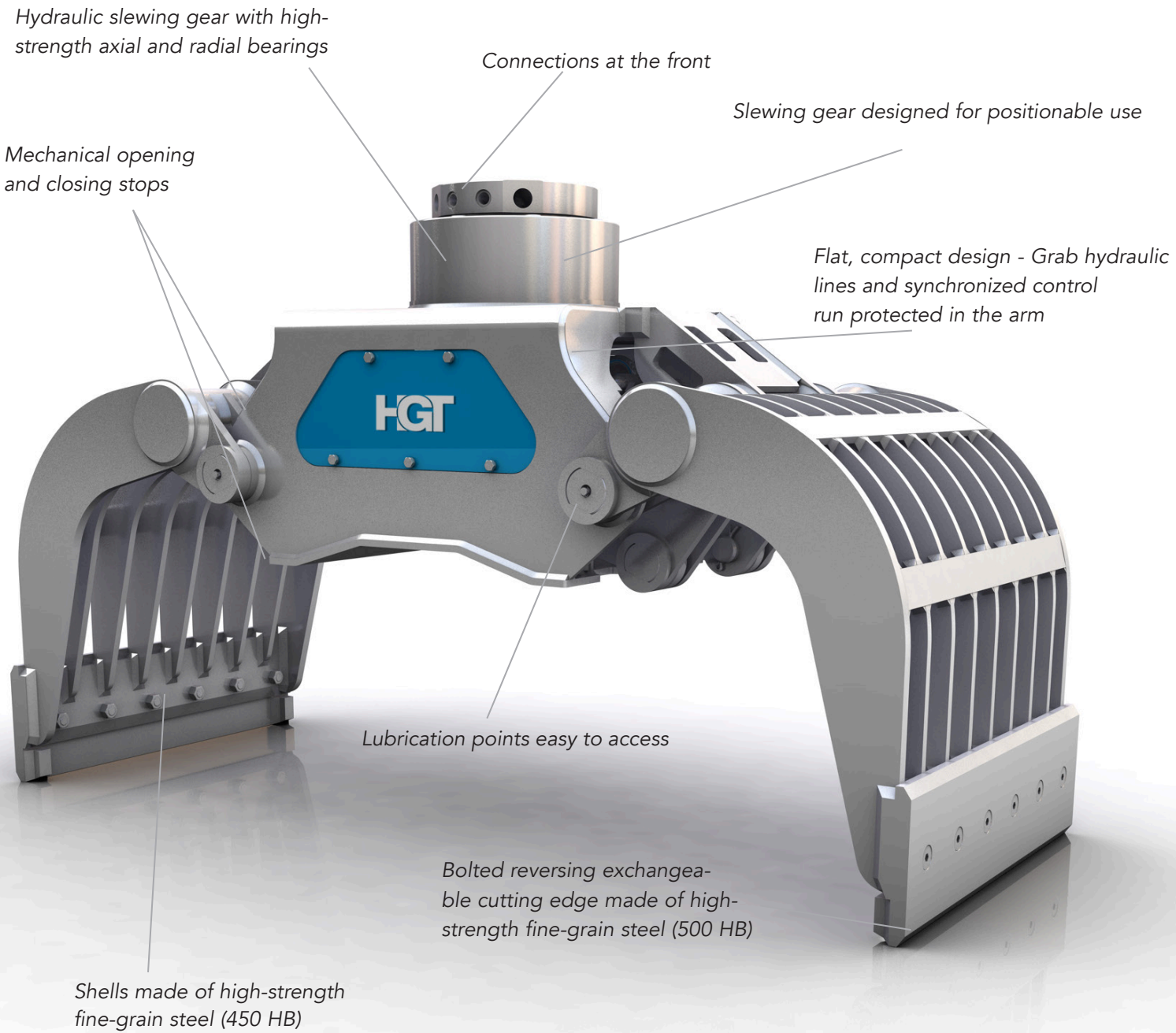

Multi-use grab for a wide range of set of handling different materials such as demolition, sorting scrap, loading and sorting and recycled materials.