

Series DG



Two-shell demolition grabs

# DG3.4

Excavator weight class (t): 15-20  
Capacity (l): 400-480

Operating pressure (bar): 350 grabbing / 140 slewing  
Clamping force (kN): 50

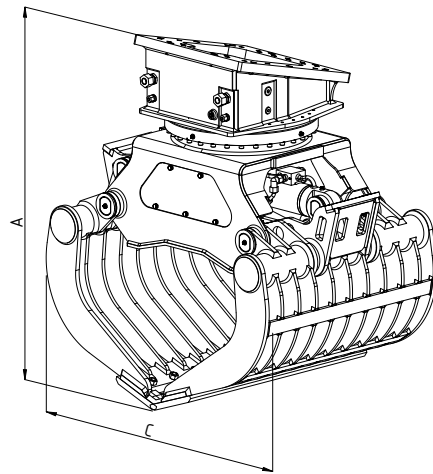
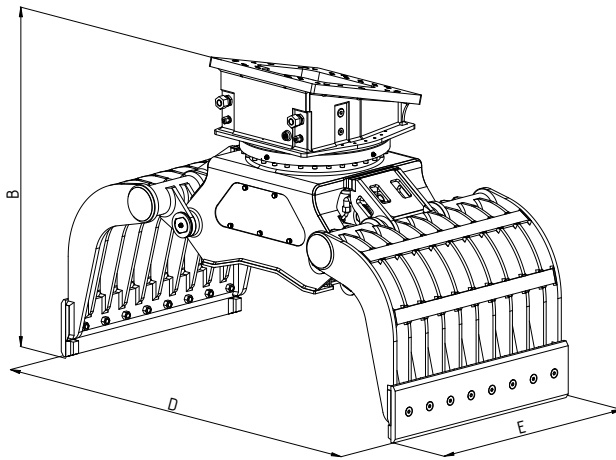

Type	Max. grabber load bearing capacity (t)	Load bearing capacity slewing gear max. (t)	Weight without adaptor plate (kg)	Dimensions (mm)				
				A	B	C	D	E
DG3.4-800	4	15	1073	1476	1357	1257	1930	800
DG3.4-1000	4	15	1240	1476	1357	1257	1930	1000
DG3.4-1200	4	15	1310	1476	1357	1257	1930	1200



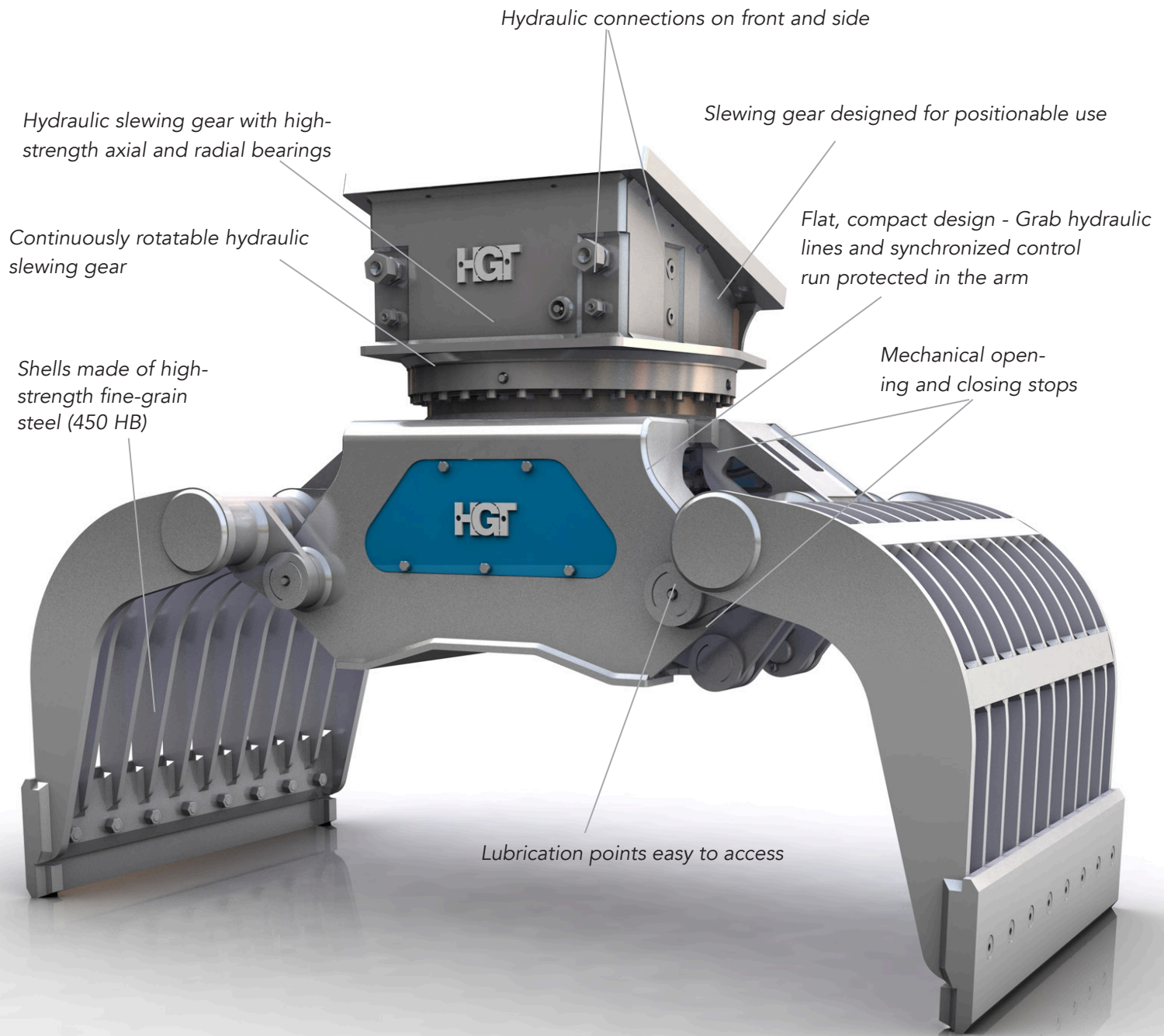

Multi-use grab for a wide range of set of handling different materials such as demolition, sorting scrap, loading and sorting and recycled materials.