

Series DG



## Two-shell demolition grabs

# DG5

Excavator weight class (t): 25-30  
Capacity (l): 760

Operating pressure (bar): 350 grabbing / 140 slewing  
Clamping force (kN): 75

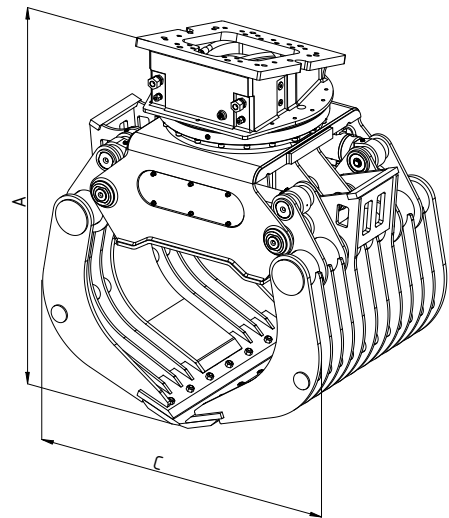
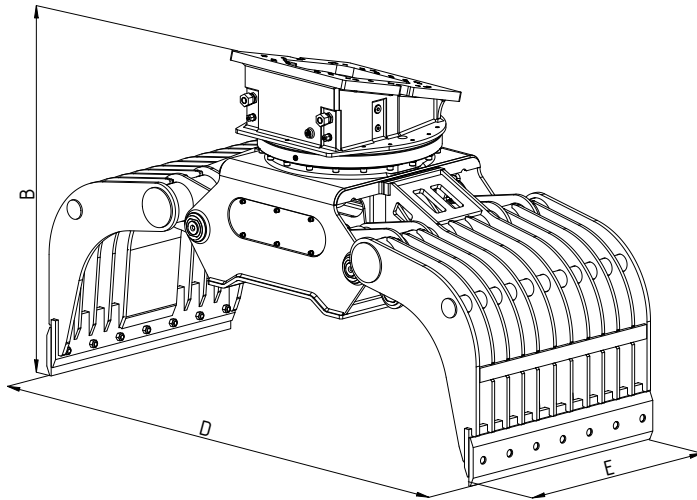

Type	Max. grabber load bearing capacity (t)	Load bearing capacity slewing gear max. (t)	Weight without adaptor plate (kg)	Dimensions (mm)				
				A	B	C	D	E
DG5	6	20	1850	1710	1495	1450	2450	1030



Hydraulic connections on front and side

Hydraulic slewing gear with high-strength axial and radial bearings

Slewing gear designed for positionable use

Continuously rotatable hydraulic slewing gear

Flat, compact design - Grab hydraulic lines and synchronized control run protected in the arm

Shells made of high-strength fine-grain steel (450 HB)

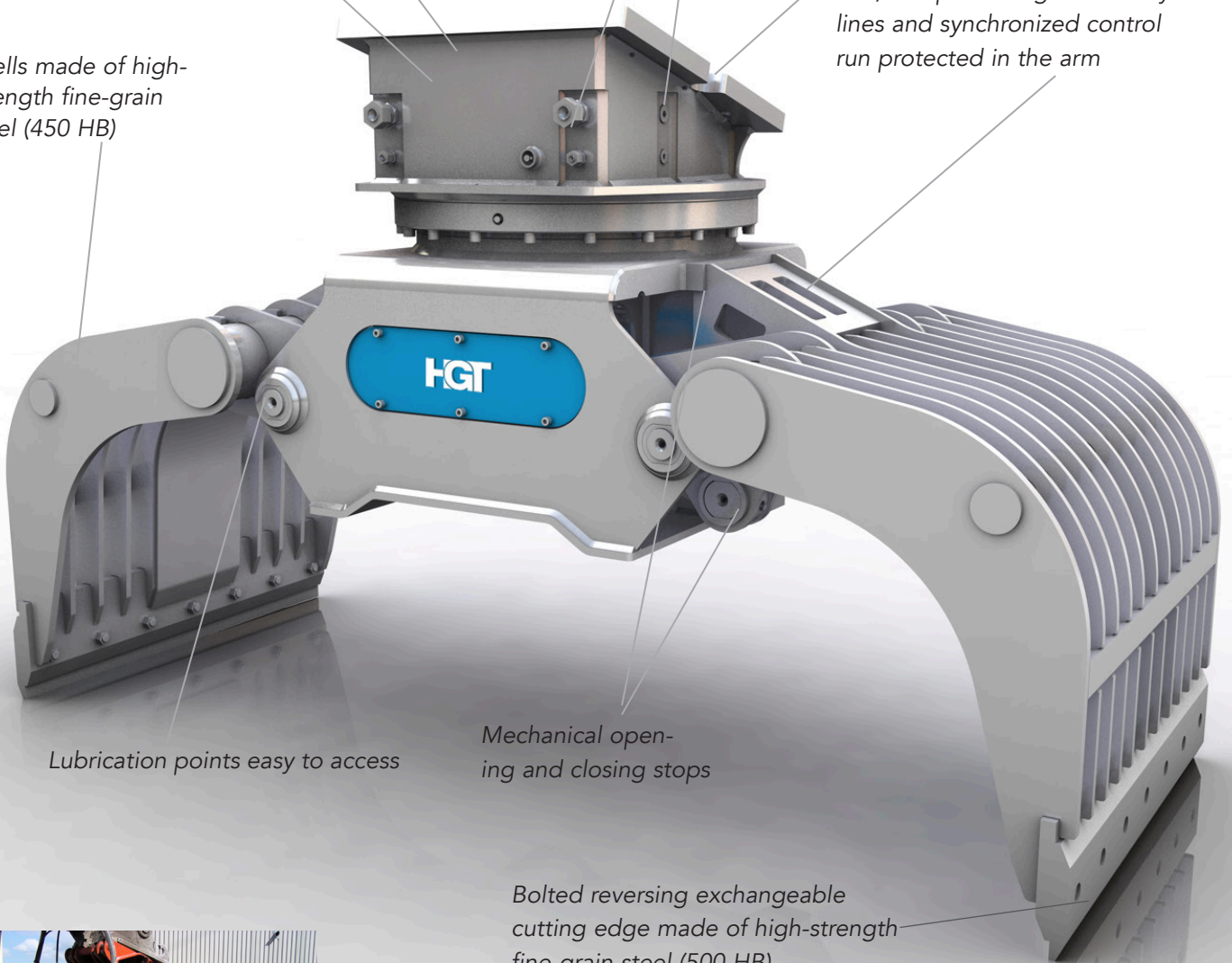

Lubrication points easy to access

Mechanical opening and closing stops

Bolted reversing exchangeable cutting edge made of high-strength fine-grain steel (500 HB)



Multi-use grab for a wide range of set of handling different materials such as demolition, sorting scrap, loading and sorting and recycled materials.