

Series DG



Two-shell demolition grabs

DG6

Excavator weight class (t): 29-40
Capacity (l): 950

Operating pressure (bar): 350 grabbing / 140 slewing
Clamping force (kN): 75

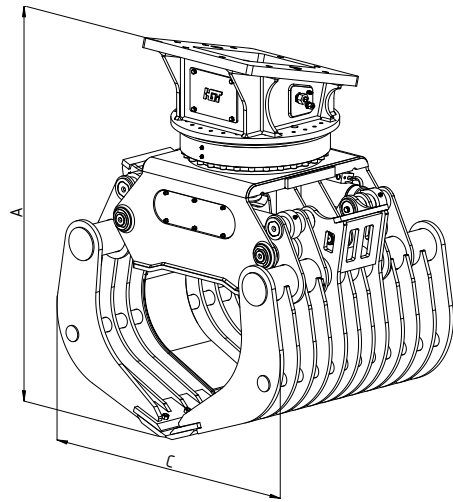
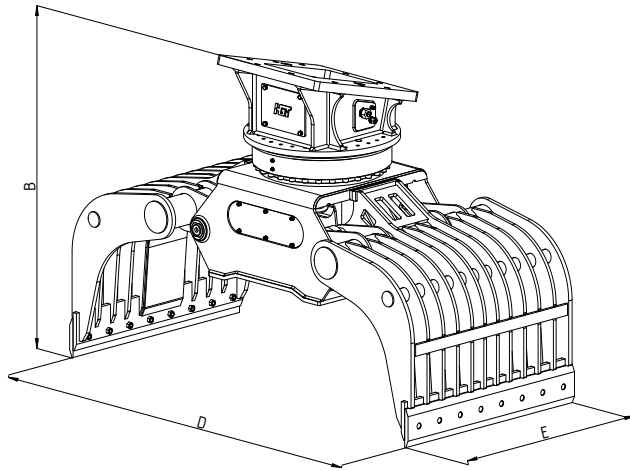

Type	Max. grabber load bearing capacity (t)	Load bearing capacity slewing gear max. (t)	Weight without adaptor plate (kg)	Dimensions (mm)				
				A	B	C	D	E
DG6	8	30	2180	1820	1625	1535	2500	1230



Hydraulic connections on the side

Hydraulic slewing gear with high-strength axial and radial bearings

Slewing gear designed for positionable use

Shells made of high-strength fine-grain steel (450 HB)

Flat, compact design - Grab hydraulic lines and synchronized control run protected in the arm



Lubrication points easy to access

Mechanical opening and closing stops

Bolted reversing exchangeable cutting edge made of high-strength fine-grain steel (500 HB)



Multi-use grab for a wide range of set of handling different materials such as demolition, sorting scrap, loading and sorting and recycled materials.