

Series DWP



Hydraulic slewing gear

DWP10

Weight (kg): 125

max. axial static load bearing capacity (t): 10

max. axial dynamic load bearing capacity (t): 6

Torque (140bar) (Nm): 2354

Speed max. (rpm): 18

Operating pressure max. (bar): 350 Rotating union /
140 Rotary function

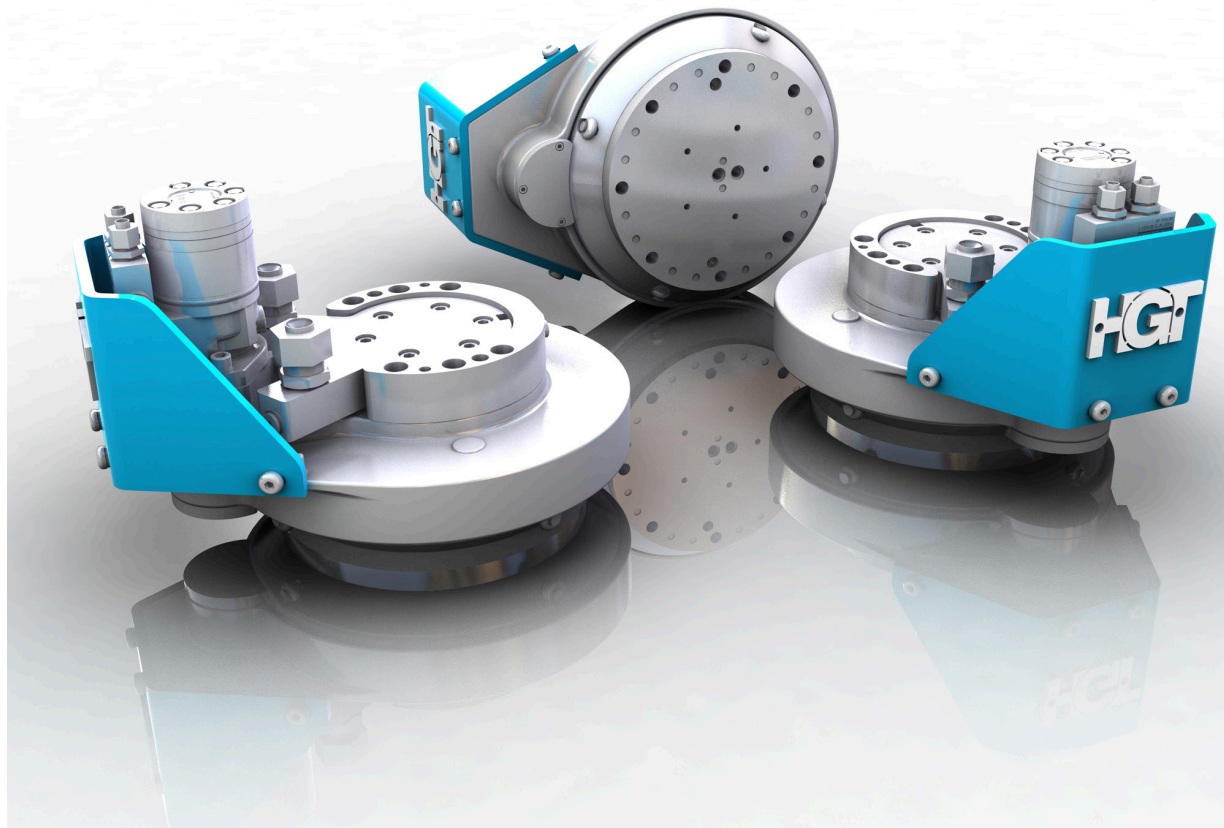
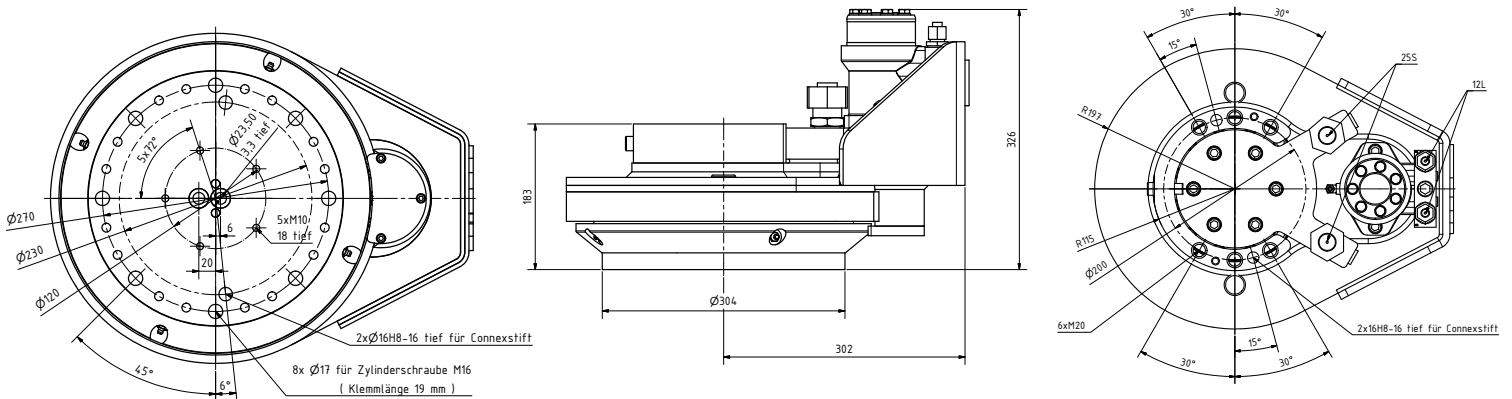



Connections for slewing

Torque motor

Hose protection plate for the hydraulic connections on the slewing gear

Open/close the connections



The DWP-10 slewing gear has been designed for use on hydraulic attachments for hydraulic excavators, as well as for mobile and stationary handling machines. The DWP-10 takes over three functions for the operation of the attachment:

1. Endless hydraulic rotary drive
2. Hydraulic rotary union
3. axial as well as radial support of the attachment in rotary operation