

Series DWP



Hydraulic slewing gear

# DWP15-2

Weight (kg): 255

max. axial static load bearing capacity (t): 15

max. axial dynamic load bearing capacity (t): 8

Torque (140bar) (Nm): 4463

Speed max. (rpm): 15

Operating pressure max. (bar): 350 Rotating union /  
140 Rotary function

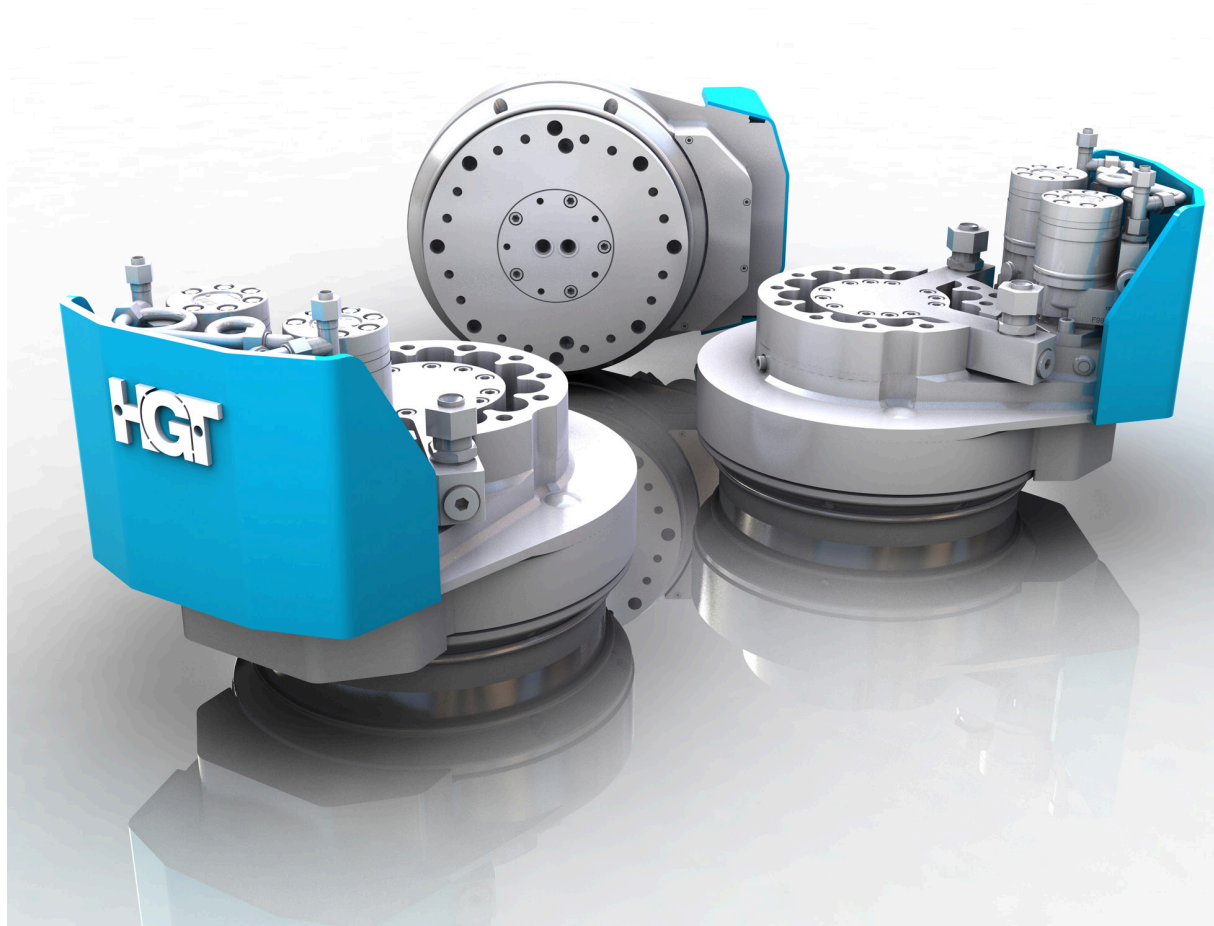
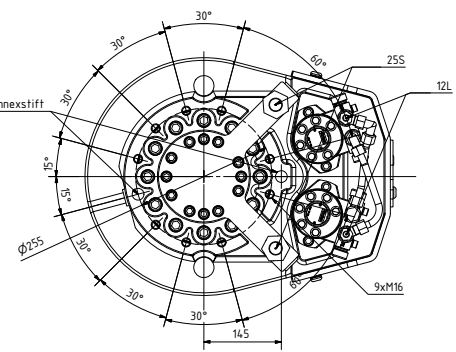
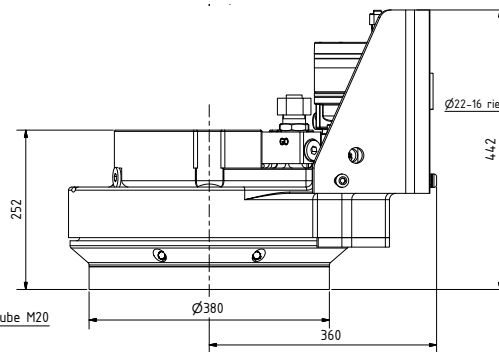
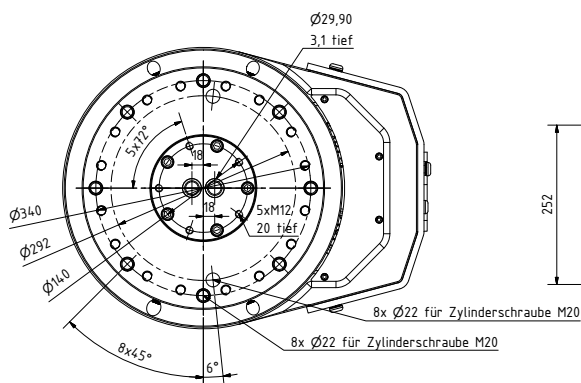

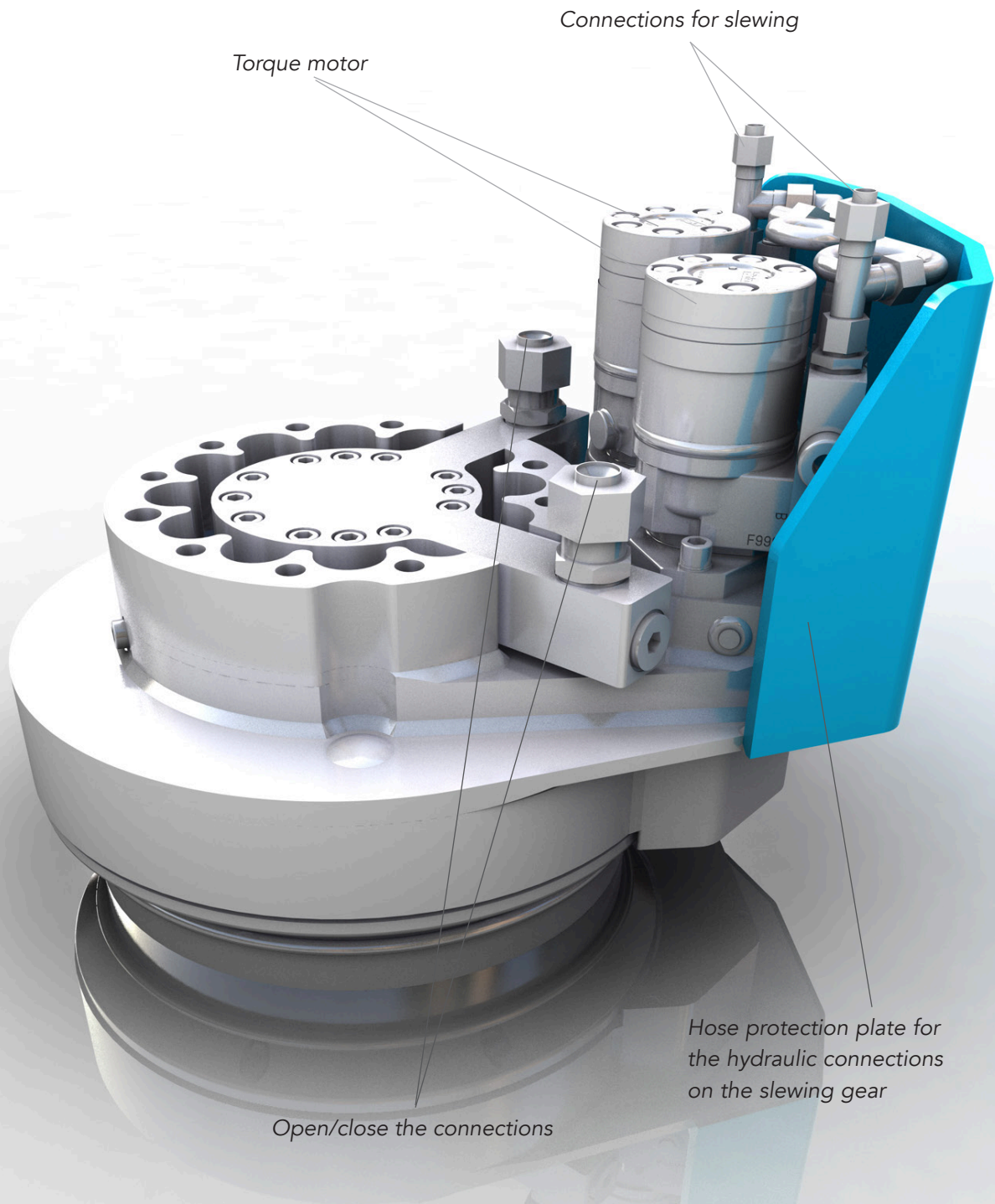

The DWP-15-2 slewing gear has been designed for use on hydraulic attachments for hydraulic excavators, as well as for mobile and stationary handling machines. The DWP-15-2 takes over three functions for the operation of the attachment:

1. Endless hydraulic rotary drive
2. Hydraulic rotary union
3. axial as well as radial support of the attachment in rotary operation