

Series DWP



Hydraulic slewing gear

# DWP40-2

Weight incl. ASS (kg): 859

max. axial dynamic load bearing capacity (t): 40

Torque (140bar) (Nm): 8448

Speed max. (rpm): 8

Operating pressure max. (bar): 350 Rotating union /  
140 Rotary function

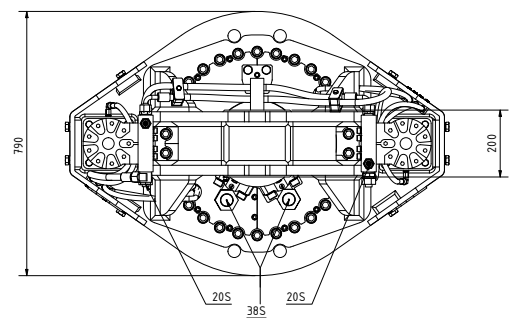
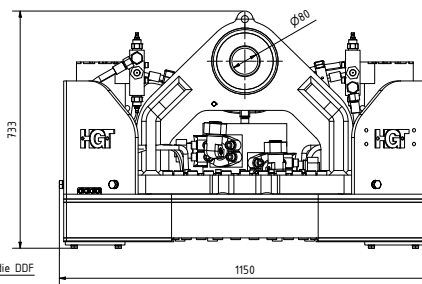
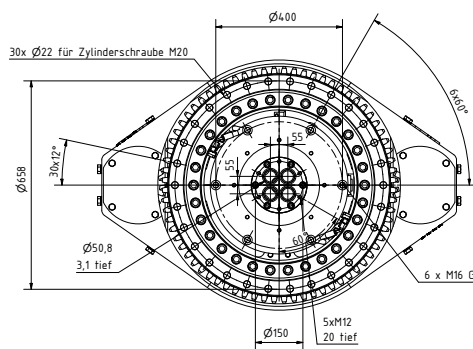

Torque motor

Connecting piece for cardanic grab suspension

Torque motor

Connections for slewing

Open/close the connections

Hose protection plate for the hydraulic connections on the slewing gear

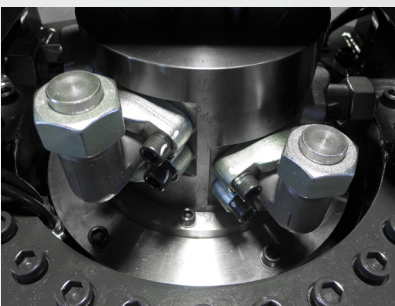
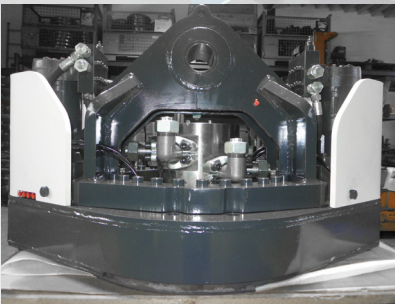

The DWP-40-2 slewing gear has been designed for use on hydraulic attachments for hydraulic excavators, as well as for mobile and stationary handling machines. The DWP-40-2 takes over three functions for the operation of the attachment:

1. Endless hydraulic rotary drive
2. Hydraulic rotary union
3. axial as well as radial support of the attachment in rotary operation