

Series TG, TGR and FTG



Two-shell wood loading grabs

FTG4.6

Excavator weight class (t): 35-60

Speed (rpm): 10

Load bearing capacity (t): Grab: 10 / Slewing gear: 15

Log length (m): 12

Operating pressure (bar): 350 grabbing / 140 slewing

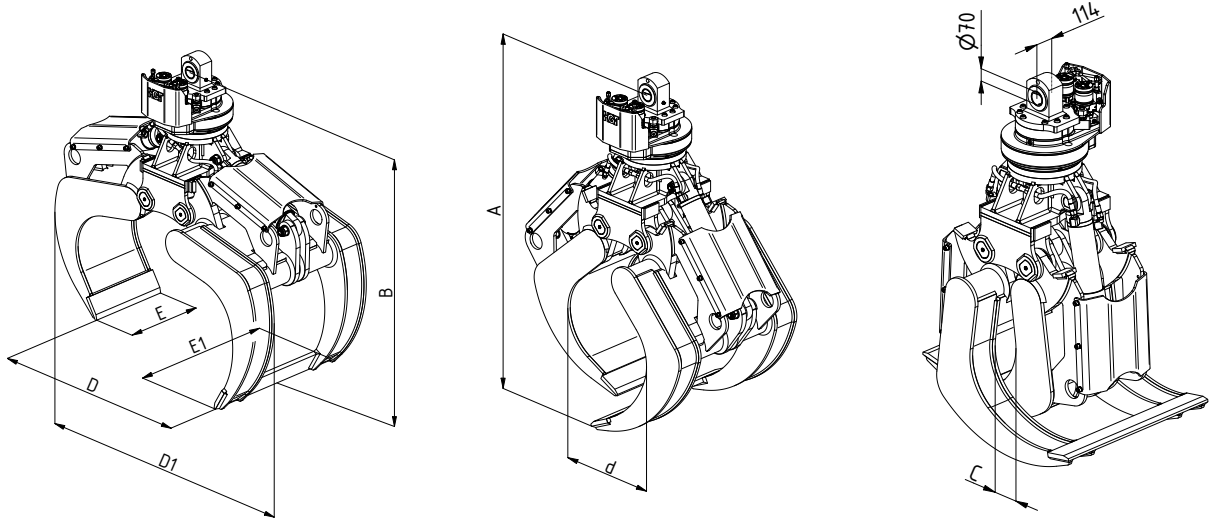

Type	Capacity (m ²)	Weight (kg)	Dimensions (mm)					
			A	B	C	d	D/D1	E/E1
FTG4.6-650	0.65	1830	2012	1894	40	880	1237/1933	550/1005



Connecting piece for cardanic grab suspension

Continuously rotatable hydraulic slewing gear

Motor protection plate to protect the hydraulic connections on the slewing gear

Synchronized control run arranged protected in the arm

- Straps HB 450
- Side parts S 690 QL
- Bottom edge HB 500



Handling grab designed especially for single length logs. Due to the shape of the tines, TG wood grabs can easily pick up one or more logs of different diameter from the ground, a stack or HGV and confidently hold and handle them.