

Series MP



Two-shell universal grabs

MP3.3

Excavator weight class (t): 9-15
Capacity (l): 360

Operating pressure (bar): 350 grabbing / 250 slewing
Clamping force (kN): 55

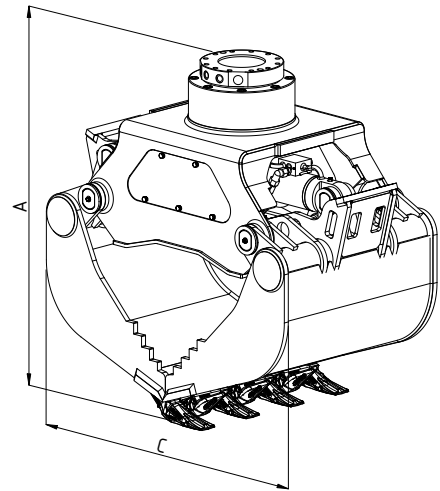
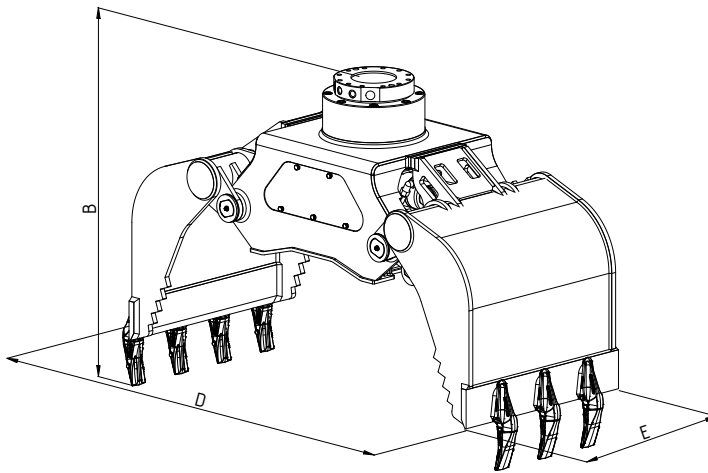

Type	Max. grabber load bearing capacity (t)	Load bearing capacity rotary motor max. (t)	Weight without adapter plate (kg)	Number of teeth	Dimensions (mm)				
					A	B	C	D	E
MP3.3-800	4	15	938	7	1258	1293	1200	1930	800

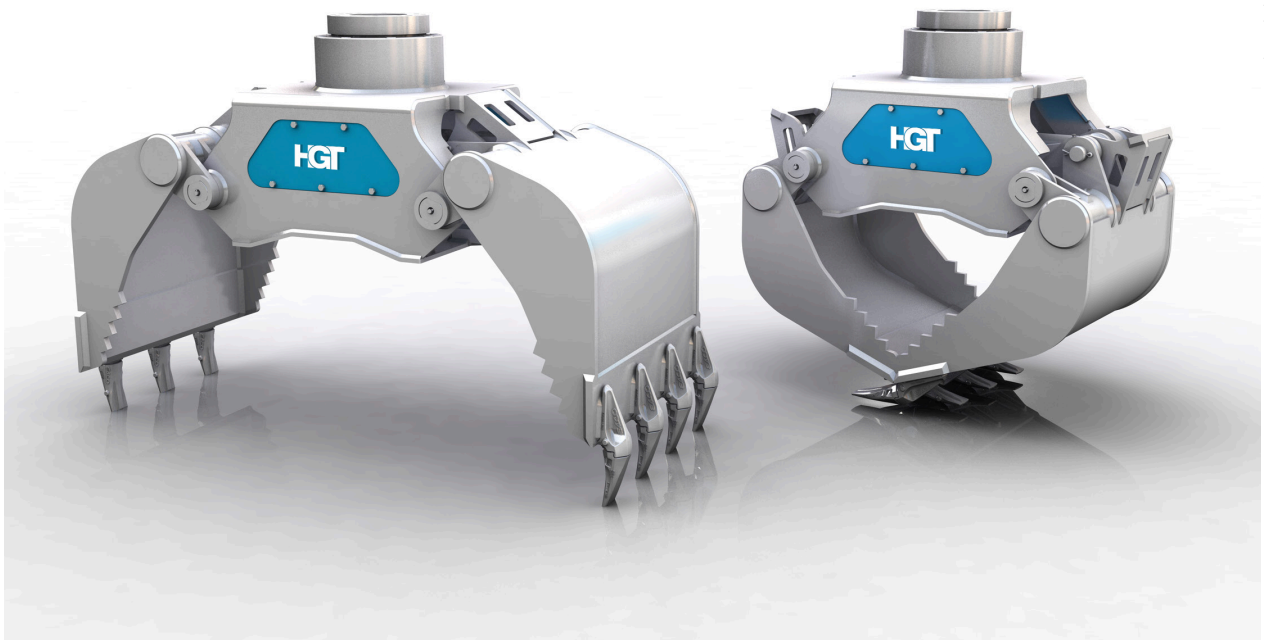

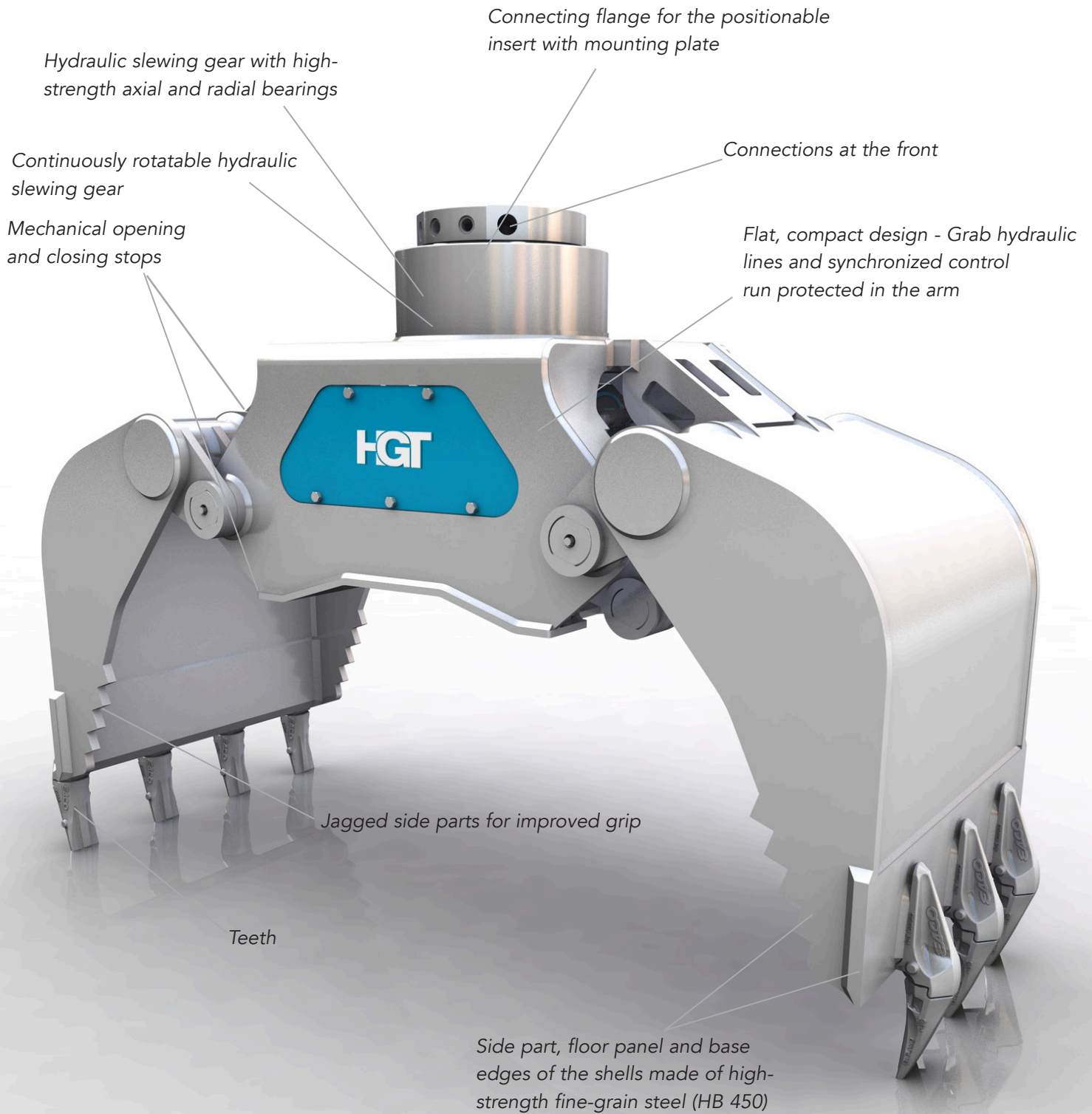

Multi-use grab for a wide range of applications for handling different materials such as stone-setting tasks, sorting construction scrap, loading and sorting recycling materials, earth excavation and loading coarse bulk goods, loading bushes and shrubs.