

Series MP



Two-shell universal grabs

MP3.4

Excavator weight class (t): 15-20
Capacity (l): 360

Operating pressure (bar): 350 grabbing / 140 slewing
Clamping force (kN): 55

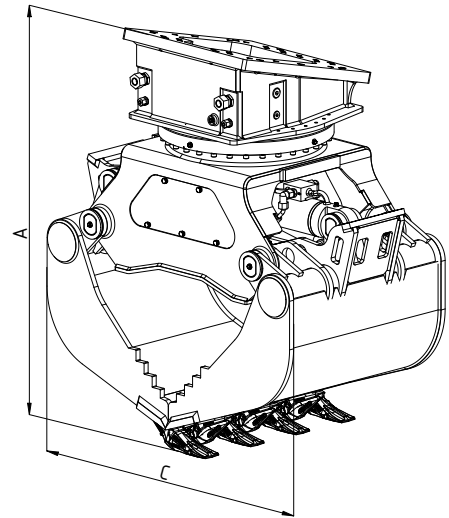
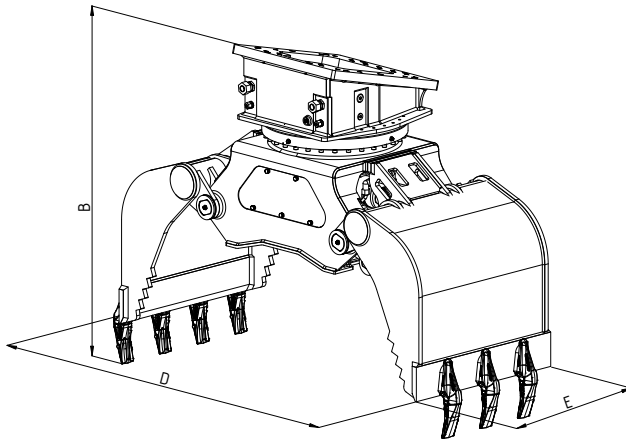

Type	Max.grab-ber load bearing capacity (t)	Load bear- ing capacity slewing gear max. (t)	Weight with- out adapter plate (kg)	No. of Teeth	Dimensions (mm)				
					A	B	C	D	E
MP3.4-800	4	15	1070	7	1470	1500	1200	1930	800



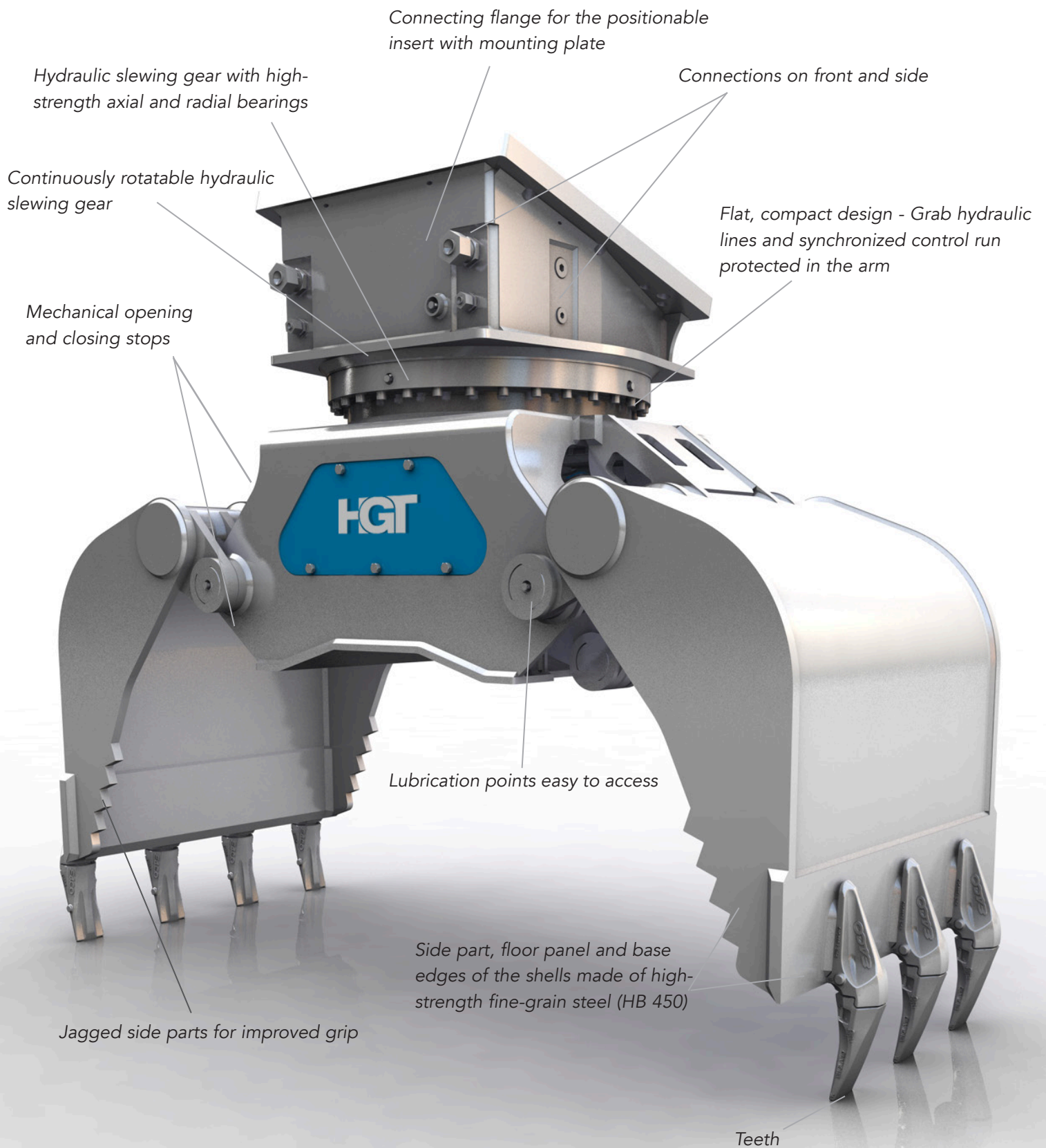

Multi-use grab for a wide range of applications for handling different materials such as stone-setting tasks, sorting construction scrap, loading and sorting recycling materials, earth excavation and loading coarse bulk goods, loading bushes and shrubs.