

Series MT



Orange loading grab

MT3.2-4

Excavator weight class (t): 10-25

Operating pressure (bar): 350 grabbing / 140 slewing

Load bearing capacity (t): Grab: 2 / Slewing gear: 10

Speed (rpm): 15

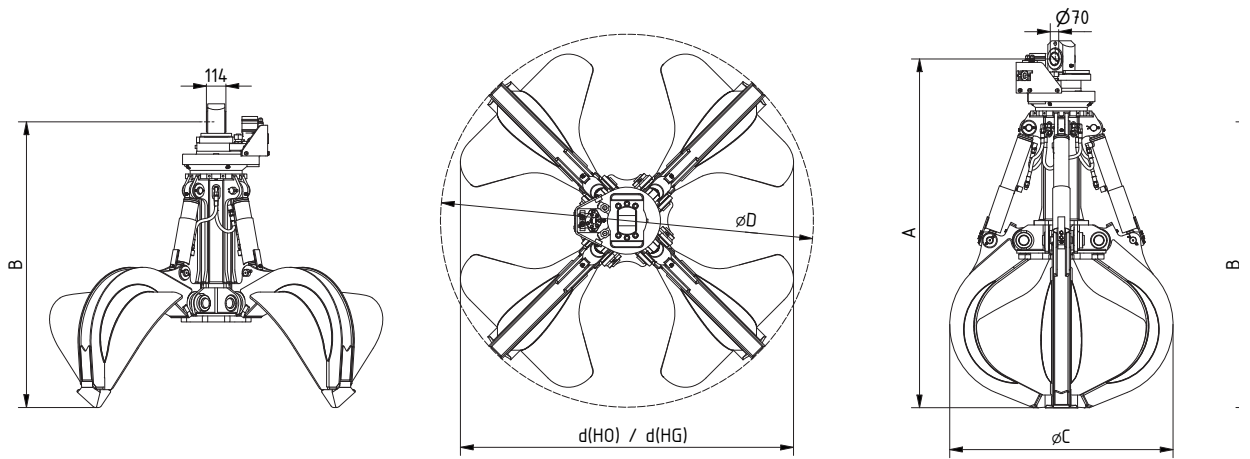

Type	Capacity (l)	Weight (kg)		Dimensions (mm)					
		HO	HG	A	B	C	D	d(HO)	d(HG)
MT3.2-500-4	500	834	956	2046	1676	1310	2187	1610	1954



Half open (HO)



Half closed (HG)

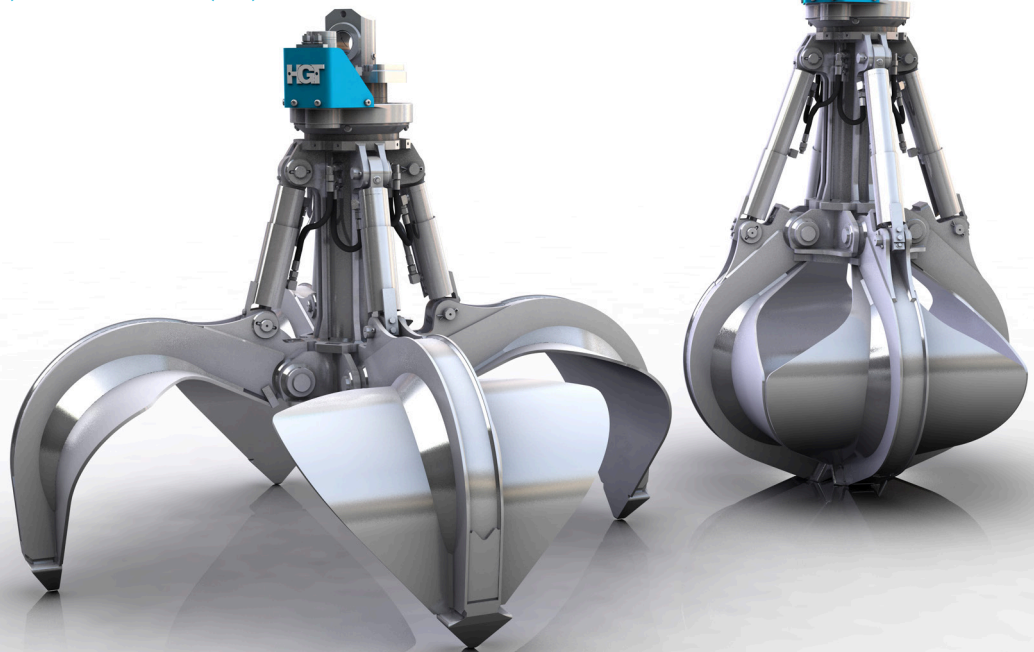

Connecting piece for cardanic grab suspension

Continuously rotatable hydraulic slewing gear

Hose protection plate for the hydraulic connections on the slewing gear

Lifting cylinder with dampened end position

Piston rod protection

Large-area shell rivet point bearings

The shells are exchangeable within the entire series and made completely of HB 450

**Optional with hose protection plates*

Shell tips made of manganese steel

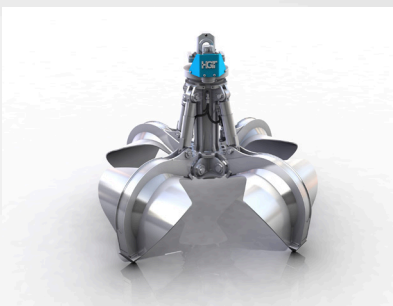

Special handling and sorting grab for large and bulky material such as found in quarries, scrap sorting, waste and recycling facilities. Available as 4 and 5 arm version.