

Series MT



Orange loading grab

MT6.6-5

Excavator weight class (t): 70-100

Operating pressure (bar): 350 grabbing / 140 slewing

Load bearing capacity (t): Grab: 15 / Slewing gear: 35

Speed (rpm): 10

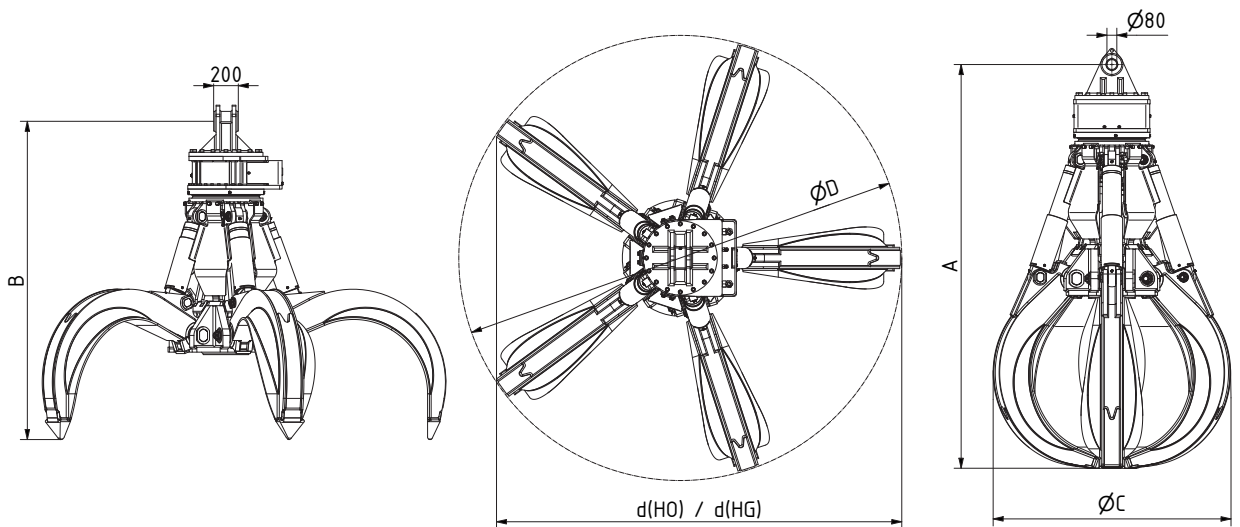

Type	Capacity (l)	Weight (kg)			Dimensions (mm)					
		HO	G	A	B	C	D	d(HO)	d(HG)	
MT6.6-2500-5	2500	4025	4400	3335	2545	2270	3910	3575	3625	
MT6.6-3000-5	3000	4060	4475	3440	2580	2285	4100	3730	3810	
MT6.6-3500-5	3500	4160	4665	3505	2600	2420	4220	3860	3960	



Half open (HO)



Half closed (HG)

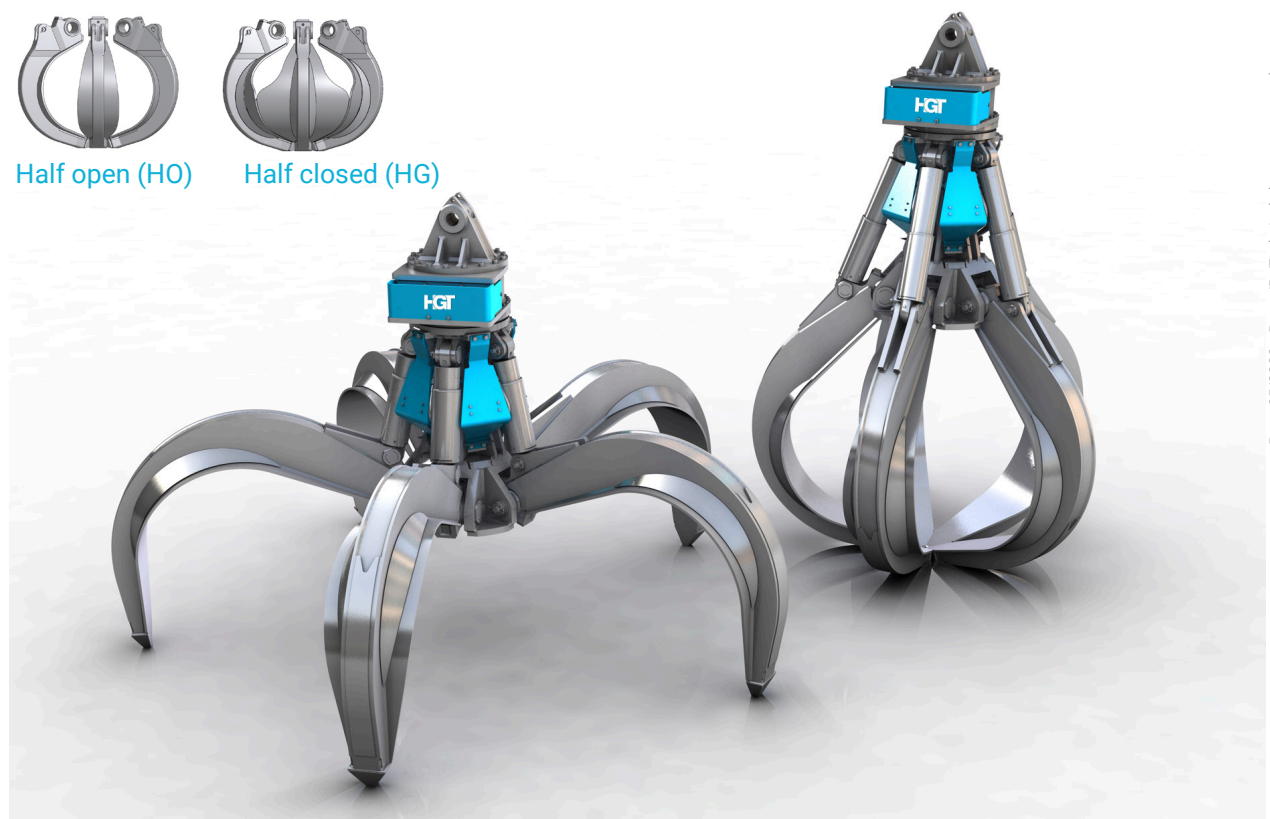

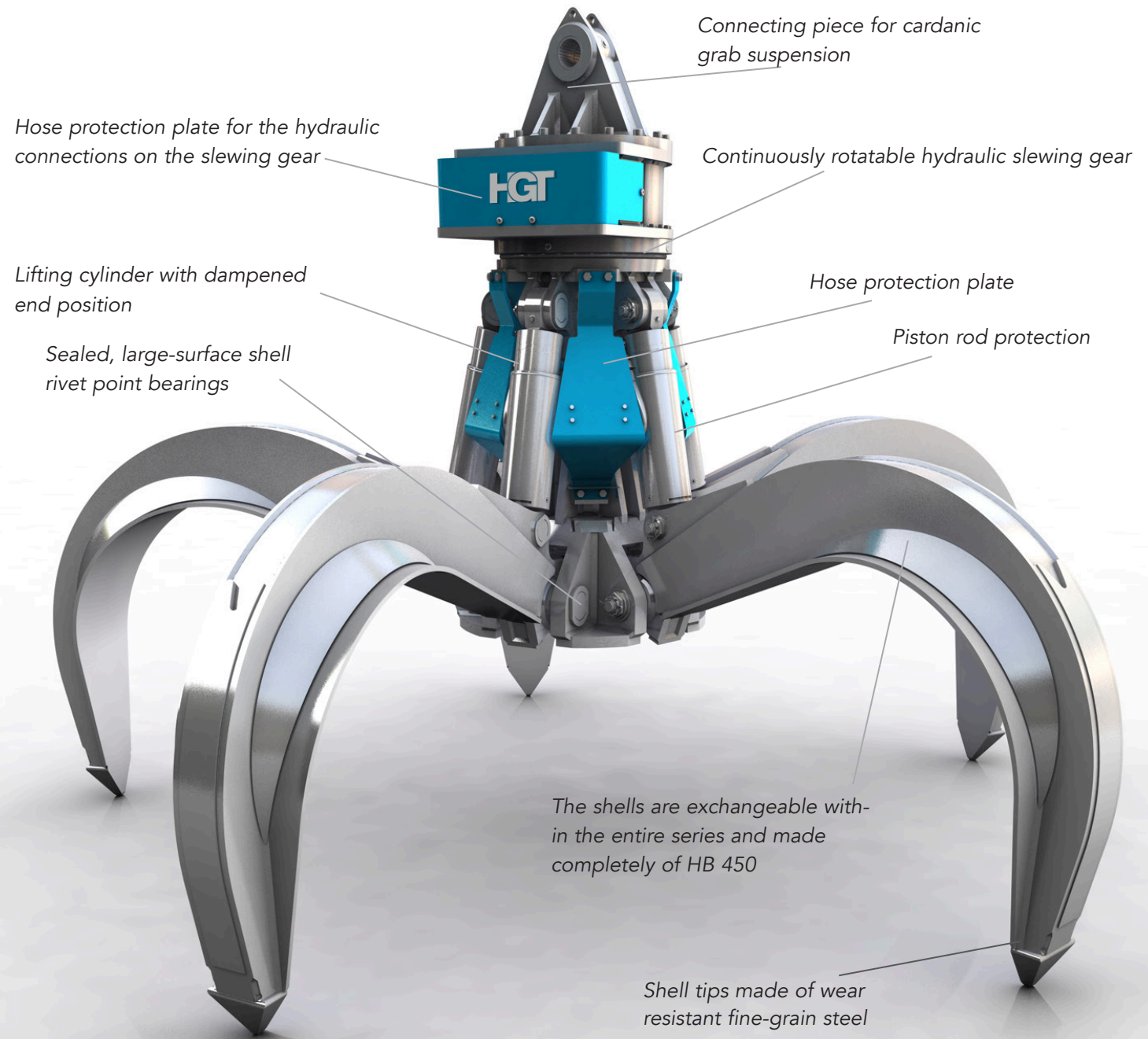

Special handling and sorting grab for large and bulky material such as found in quarries, scrap sorting, waste and recycling facilities. Available as 4 and 5 arm version.