

Series MT



Orange loading grab

MT7.6-6

Excavator weight class (t): 100-220

Operating pressure (bar): 350 grabbing / 140 slewing

Load bearing capacity (t): Grab: 15 / Slewing gear: 40

Speed (rpm): 8

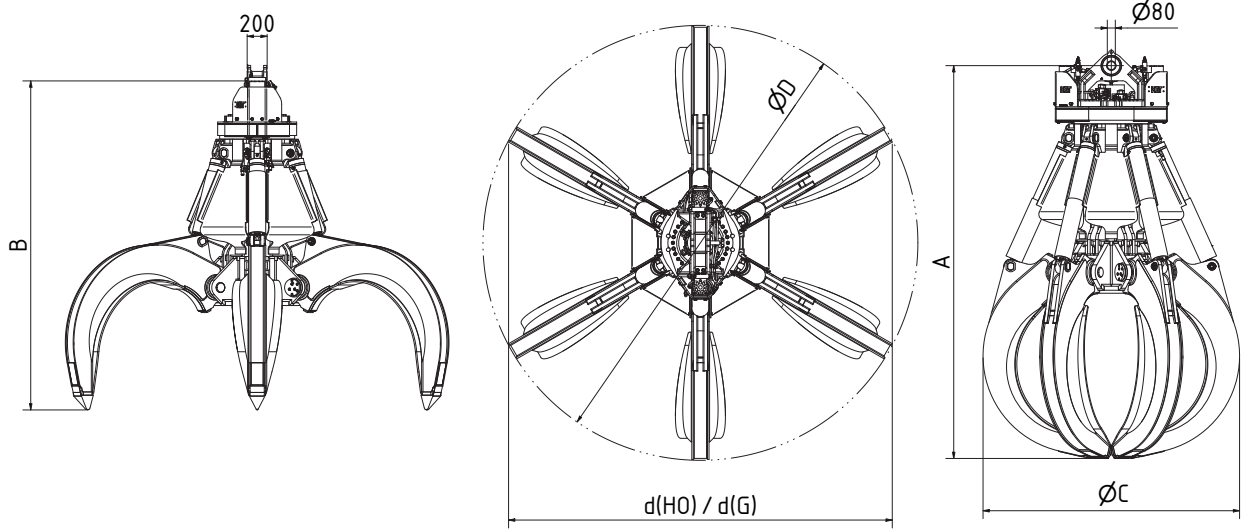

Type	Capacity (l)	Weight (kg)		Dimensions (mm)					
		HO	HG	A	B	C	D	d(HO)	d(HG)
MT7.6-3000-6	3000	7350	7700	3950	3300	2600	4350	3840	3840
MT7.6-4000-6	4000	7450	7900	4010	3325	2850	4570	4020	4020
MT7.6-5000-6	5000	7575	8160	4100	3360	3050	4740	4180	4180
MT7.6-8000-6	8000	7865	8800	4370	3480	3400	5300	4660	4660



Half open (HO)

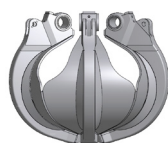

Half closed (HG)

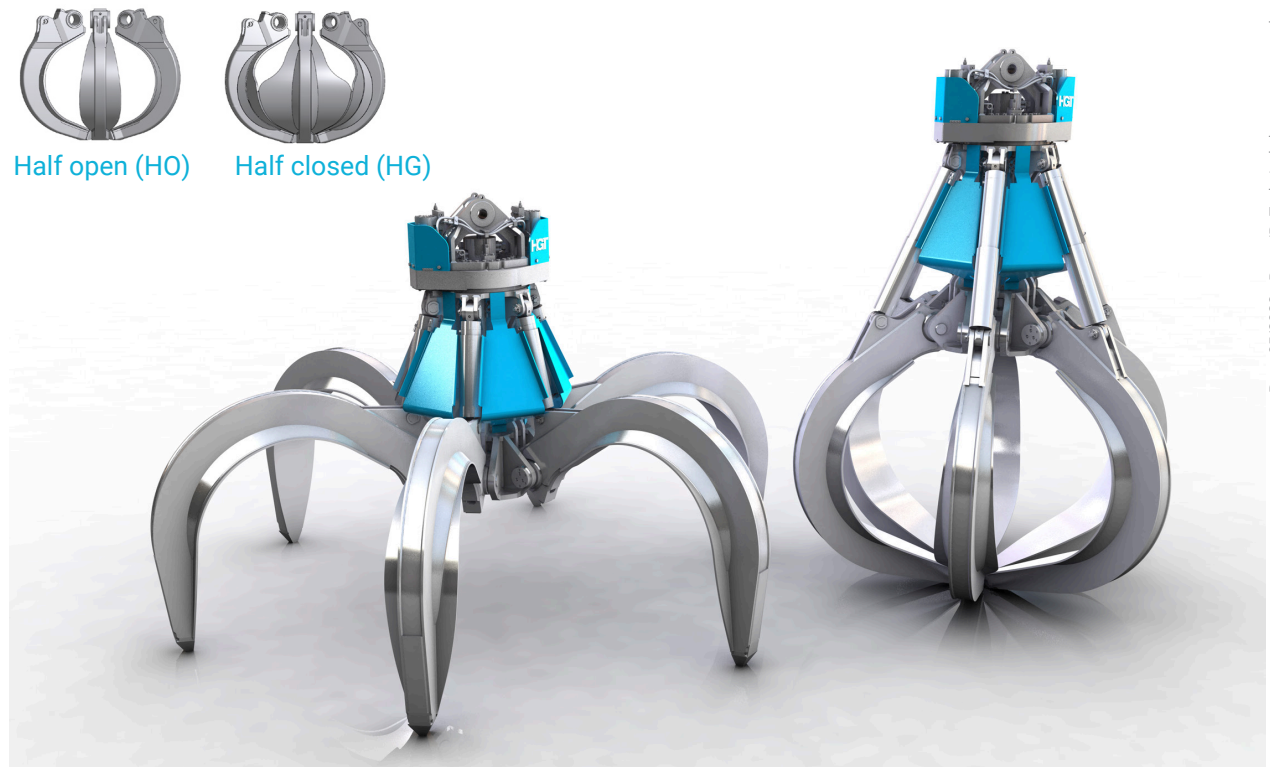

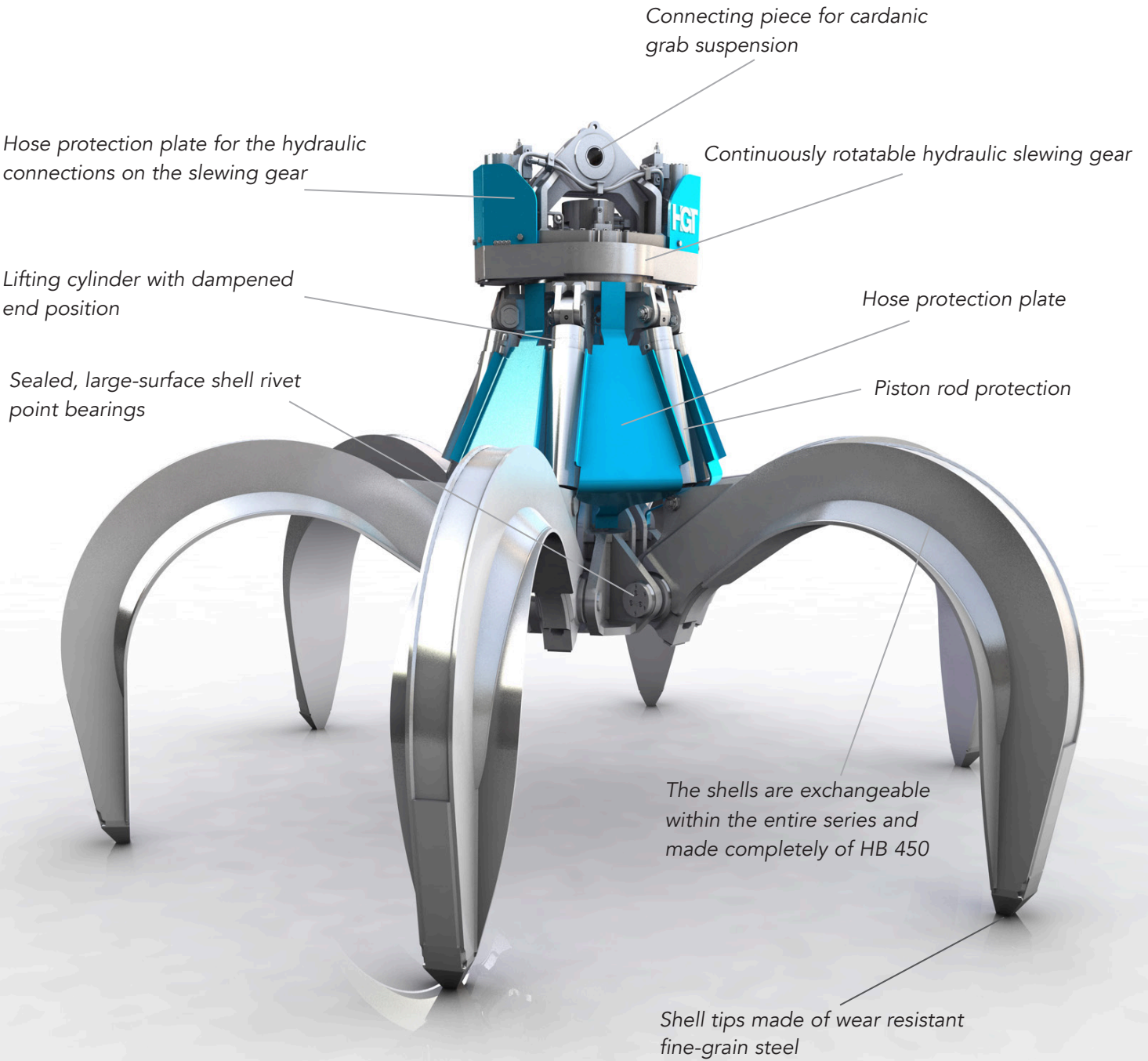

Special handling and sorting grab for large and bulky material such as found in quarries, scrap sorting, waste and recycling facilities.