

Series OQC



OQC Loading Grab

OQC-MT3.6-4

Excavator weight class (t): 15-30
Carrying capacity (t): 4

Operating pressure (bar): 350 grabbing

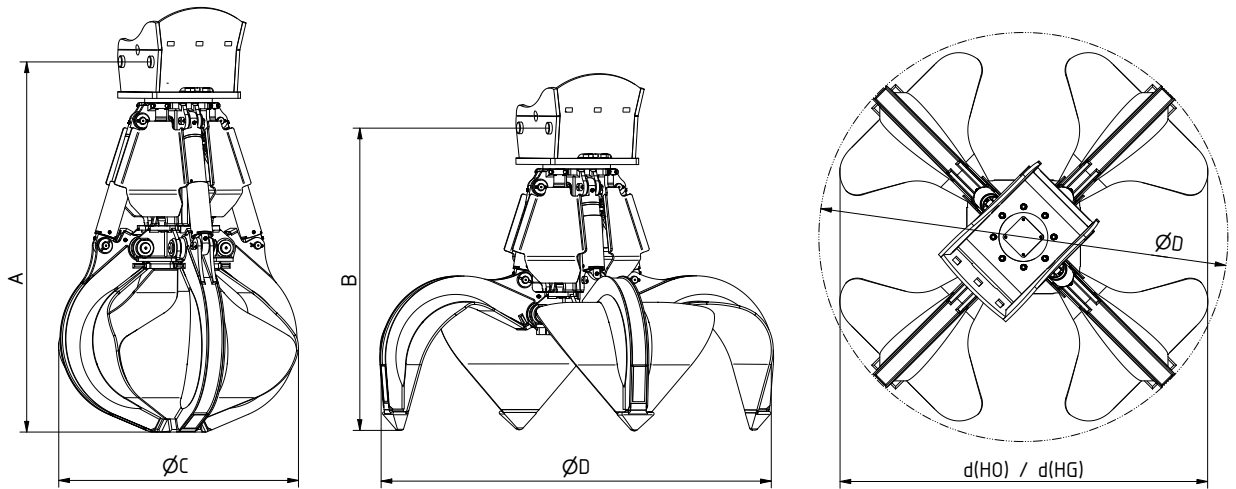

Type	Capacity (l)	Weight (kg)		Dimensions (mm)						
		HO	HG	A	B	C(HO)	C(HG)	D	d(HO)	d(HG)
OQC65-MT3.6-400-4	400	1174	1297	1981	1657	1280	1410	2109	1940	1980
OQC65-MT3.6-600-4	600	1208	1353	2083	1703	1371	1501	2295	2105	2155
OQC65-MT3.6-800-4	800	1234	1430	2186	1750	1463	1659	2483	2275	2340



OQ-quick-change adapter

Hose protection plate

Lifting cylinder with dampened end position

Piston rod protection

Mechanical opening and closing stops

The shells are exchangeable within the entire series and made completely of HB 450

HGT

Sealed, large-surface shell rivet point bearings

Shell tips made of manganese steel



Special handling and sorting grab for large and bulky material such as found in quarries, scrap sorting, waste and recycling facilities. Available as 4 and 5 arm version.