

Series OQC



OQC Loading Grab

OQC-MT3.6-5

Excavator weight class (t): 15-30
Carrying capacity (t): 4

Operating pressure (bar): 350 grabbing

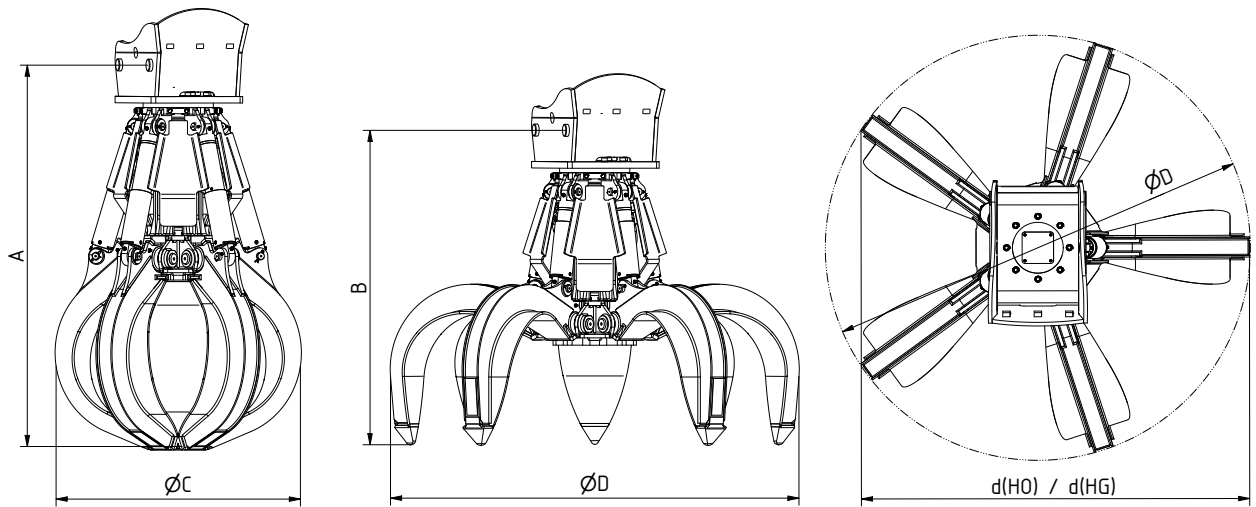

Type	Capacity (l)	Weight (kg)		Dimensions (mm)						
		HO	HG	A	B	C(HO)	C(HG)	D	d(HO)	d(HG)
OQC65-MT3.6-400-5	400	1281	1362	1981	1657	1280	1280	2109	1937	1982
OQC65-MT3.6-600-5	600	1324	1423	2083	1703	1371	1371	2295	2105	2155
OQC65-MT3.6-800-5	800	1352	1497	2186	1750	1463	1463	2483	2275	2340



OO-quick-change adapter

Hose protection plate

Lifting cylinder with dampened end position

Mechanical opening and closing stops

Piston rod protection

The shells are exchangeable within the entire series and made completely of HB 450

Sealed, large-surface shell rivet point bearings

Shell tips made of manganese steel



Special handling and sorting grab for large and bulky material such as found in quarries, scrap sorting, waste and recycling facilities. Available as 4 and 5 arm version.