

Series OQC



OQC Loading Grab

# OQC-MT4.6-4

Excavator weight class (t): 30-55  
Carrying capacity (t): 8

Operating pressure (bar): 350 grabbing

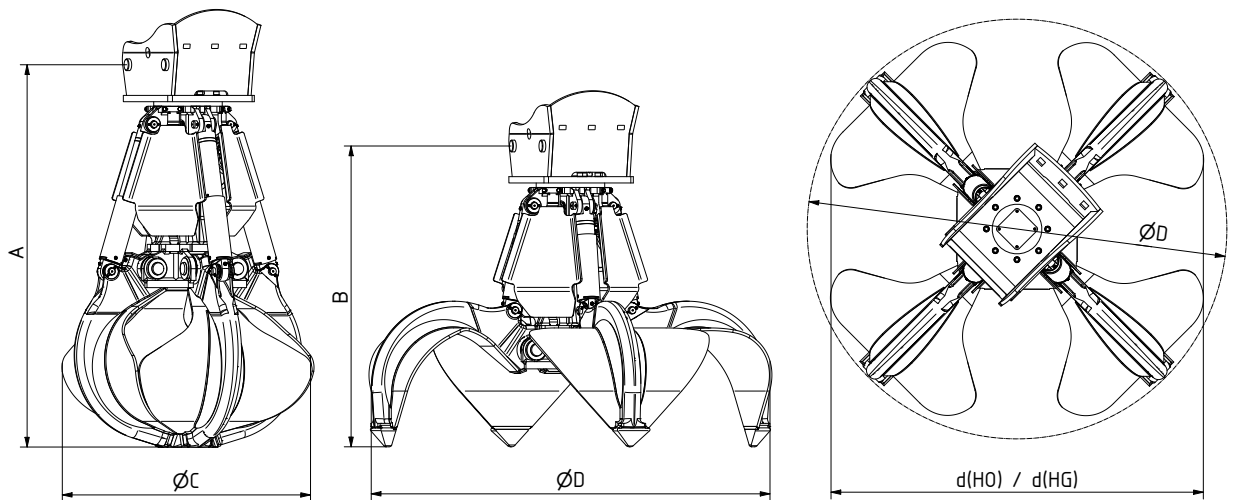

Type	Capacity (l)	Weight (kg)		Dimensions (mm)						
		HO	HG	A	B	C (HO)	C(HG)	D	d(HO)	d(HG)
OQC65-MT4.6-400-4	400	1570	1720	2032	1637	1350	1400	2160	1630	1915
OQC65-MT4.6-600-4	600	1600	1790	2117	1667	1360	1500	2320	1755	2070
OQC65-MT4.6-800-4	800	1685	1930	2252	1712	1540	1640	2600	1935	2280



OQ-quick-change adapter

Hose protection plate

Lifting cylinder with dampened end position

Piston rod protection

The shells are exchangeable within the entire series and made completely of HB 450

Mechanical opening and closing stops

Sealed, large-surface shell rivet point bearings

Shell tips made of manganese steel



Special handling and sorting grab for large and bulky material such as found in quarries, scrap sorting, waste and recycling facilities. Available as 4 and 5 arm version.