

Series OQC



OQC Loading Grab

OQC-RCS4.6

Excavator weight class (t): 20-30
Carrying capacity (t): 4
Operating pressure (bar): 350 grabbing

Bulk weight up to (t/m³): 2
Closing force max. (kN): 75

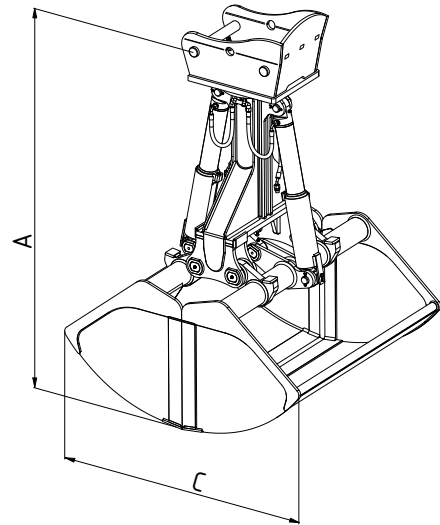
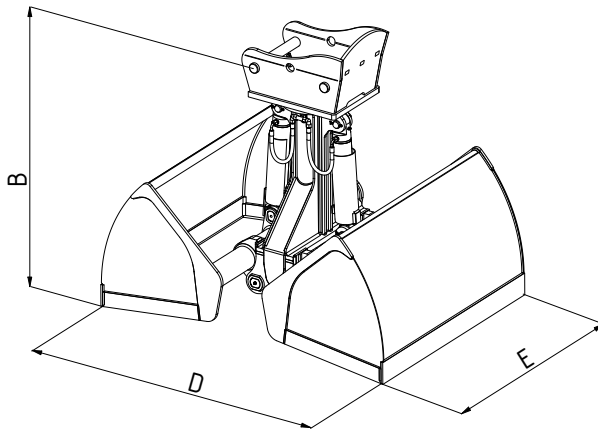

Type	Capacity - SAE (l)	Weight (kg)	Bulk density up to t/m ³	Dimensions (mm)				
				A	B	C	D	E
OQC-RCS4.6-1000	1000	1366	2.0	2311	1637	1770	2130	1100
OQC-RCS4.6-1200	1200	1467	2.0	2311	1637	1770	2130	1400
OQC-RCS4.6-1400	1400	1525	2.0	2311	1637	1770	2130	1600
OQC-RCS4.6-1600	1600	1586	1.7	2311	1637	1770	2130	1800



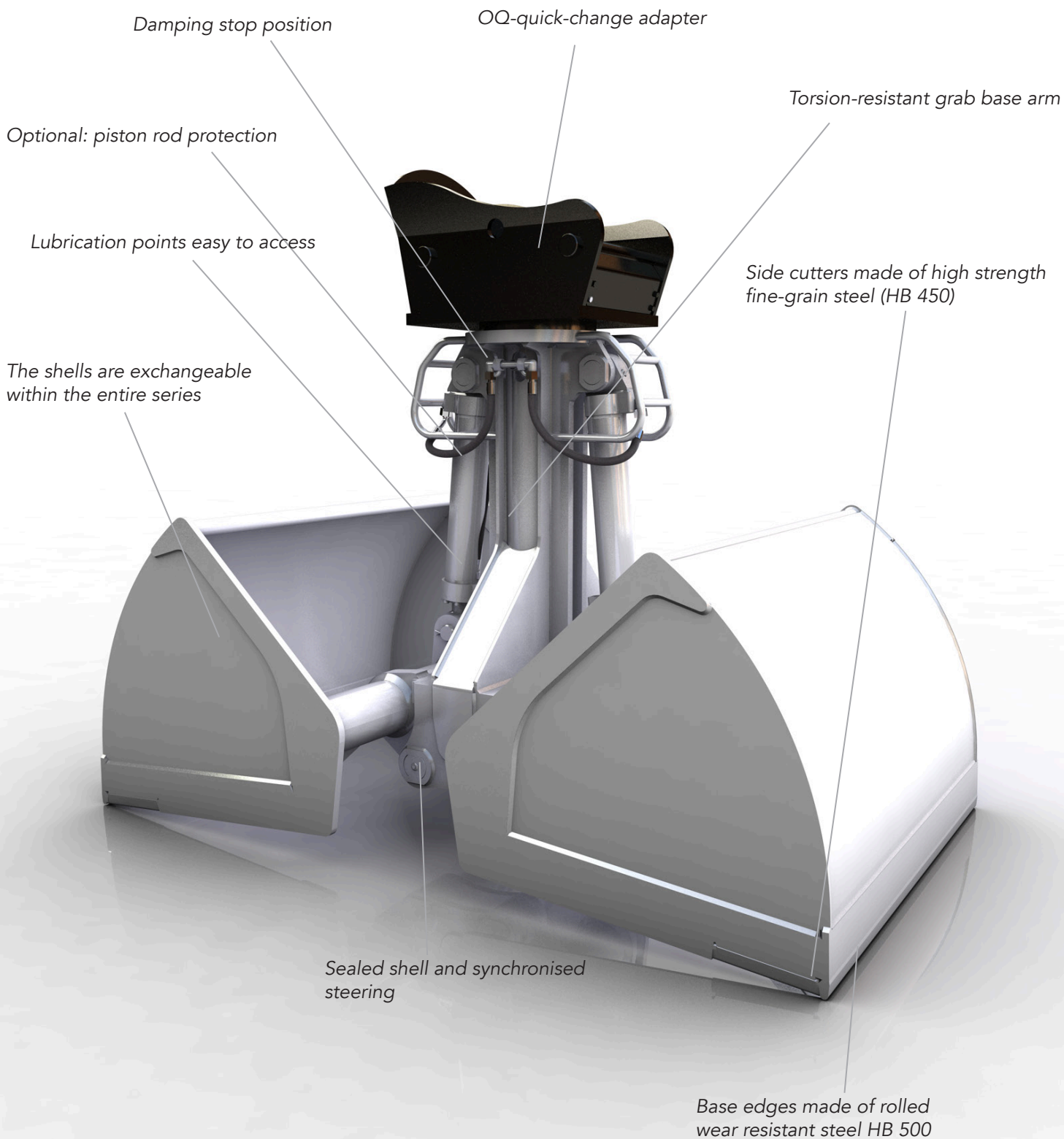

Optimized grabs for the transfer of bulk materials such as gravel, sand, pebbles, grain, feed, fertilizer, ore, coal, etc.