

Series TG, TGR and FTG



Two-shell wood loading grabs

TGR5.6

Excavator weight class (t): 35-80

Speed (rpm): 10

Load bearing capacity (t): Grab: 12 / Slewing gear: 35

Log length (m): 6-8

Operating pressure (bar): 350 grabbing / 250 slewing

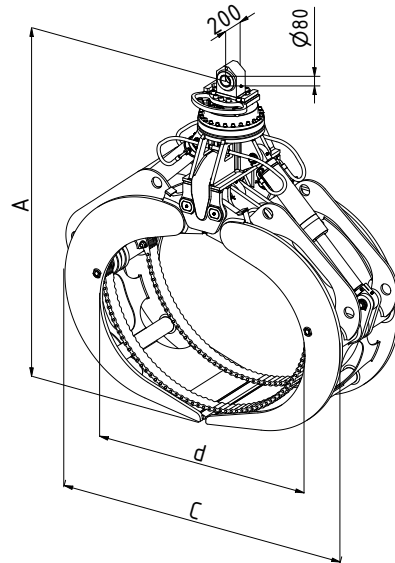
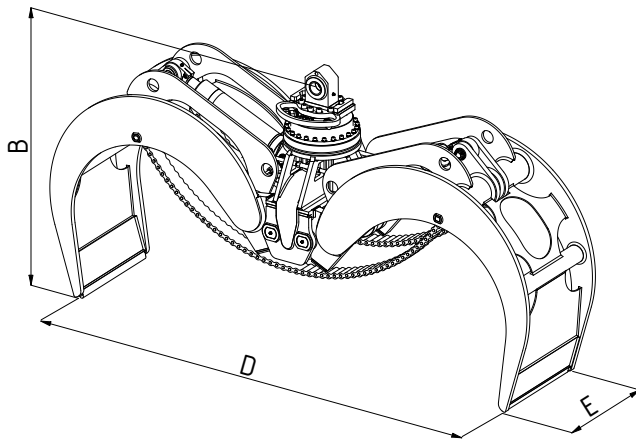

Type	Capacity (m ³)	Weight (kg)	Dimensions (mm)					
			A	B	C	d	D	E
TGR5.6-2000-C	2.0	2940	2721	1817	2672	1865	3755	800
TGR5.6-2500-C	2.5	2990	2967	1897	2672	1919	3743	800
TGR5.6-3000-C	3.0	3120	3070	1948	2672	1919	4040	800
TGR5.6-3200-C	3.2	3250	2947	1865	2661	2100	3834	800
TGR5.6-3500-C	3.5	3410	3328	1462	2886	2212	4949	800



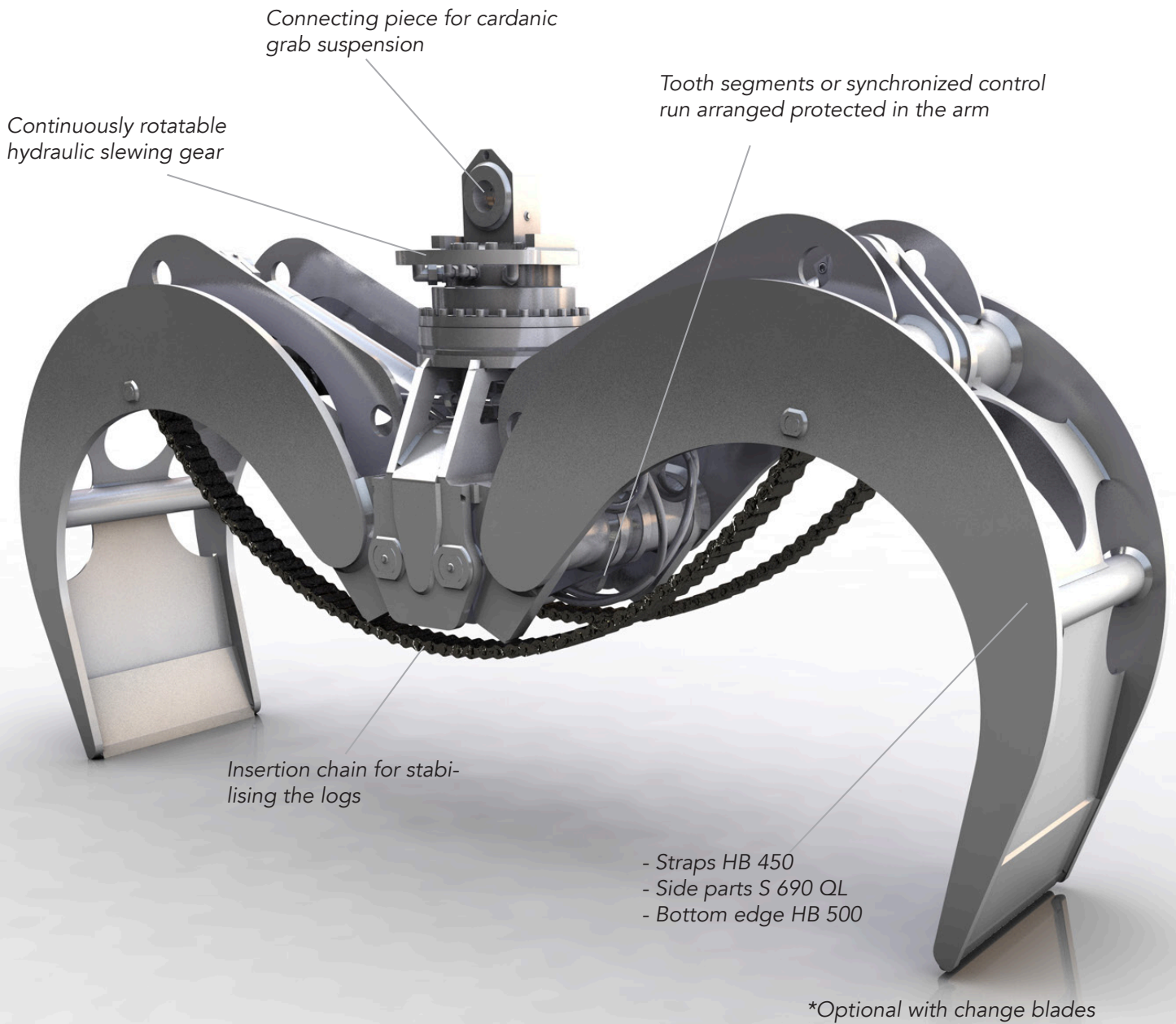

Bulk handling grab for logs and round timber. Due to the insertion chain, TGR wood grabs can easily pick up one or more logs of different diameter from the ground, a stack or HGV and confidently hold and handle them.