

Baureihe OQC



OQC-Verladegreifer

# OQC-MT4.6-5

Baggergewichtsklasse (t): 30-55  
Tragfähigkeit (t): 8

Betriebsdruck (bar): 350 Greifen

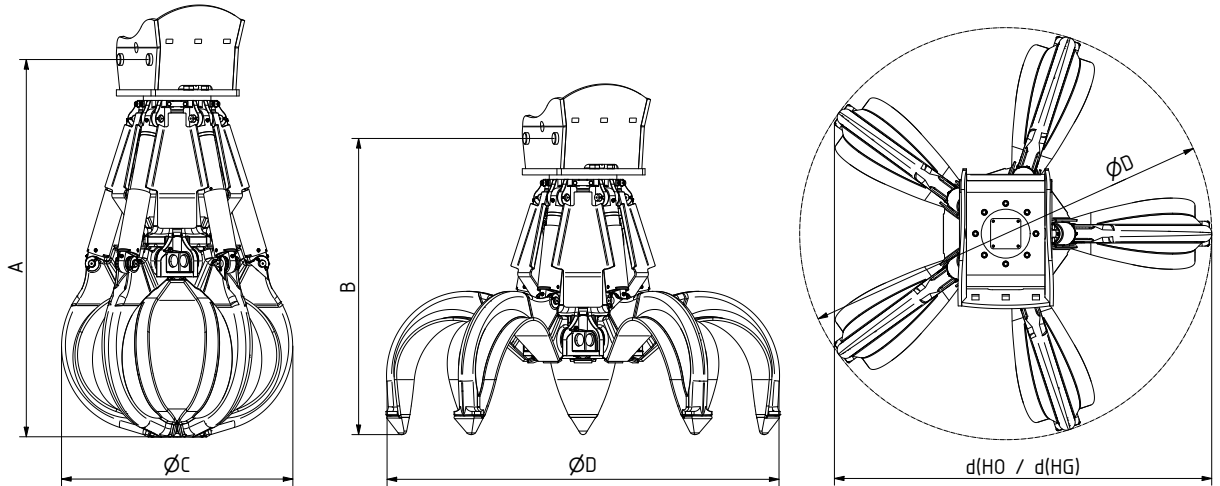

Typ	Inhalt (l)	Gewicht (kg)		Abmessungen (mm)					
		HO	HG	A	B	C	D	d(HO)	d(HG)
OQC65-MT4.6-400-5	400	1820	1920	2032	1637	1350	2160	1990	2015
OQC65-MT4.6-600-5	600	1910	2035	2117	1667	1360	2320	2120	2180
OQC65-MT4.6-800-5	800	1960	2140	2252	1712	1540	2600	2380	2420
OQC65-MT4.6-1000-5	1000	2040	2290	2362	1747	1680	2800	2565	2635
OQC65-MT4.6-1250-5	1250	2120	2440	2447	1777	1755	3095	2835	2850
OQC65-MT4.6-1400-5	1400	2200	2590	2532	1807	1780	3190	2925	3060



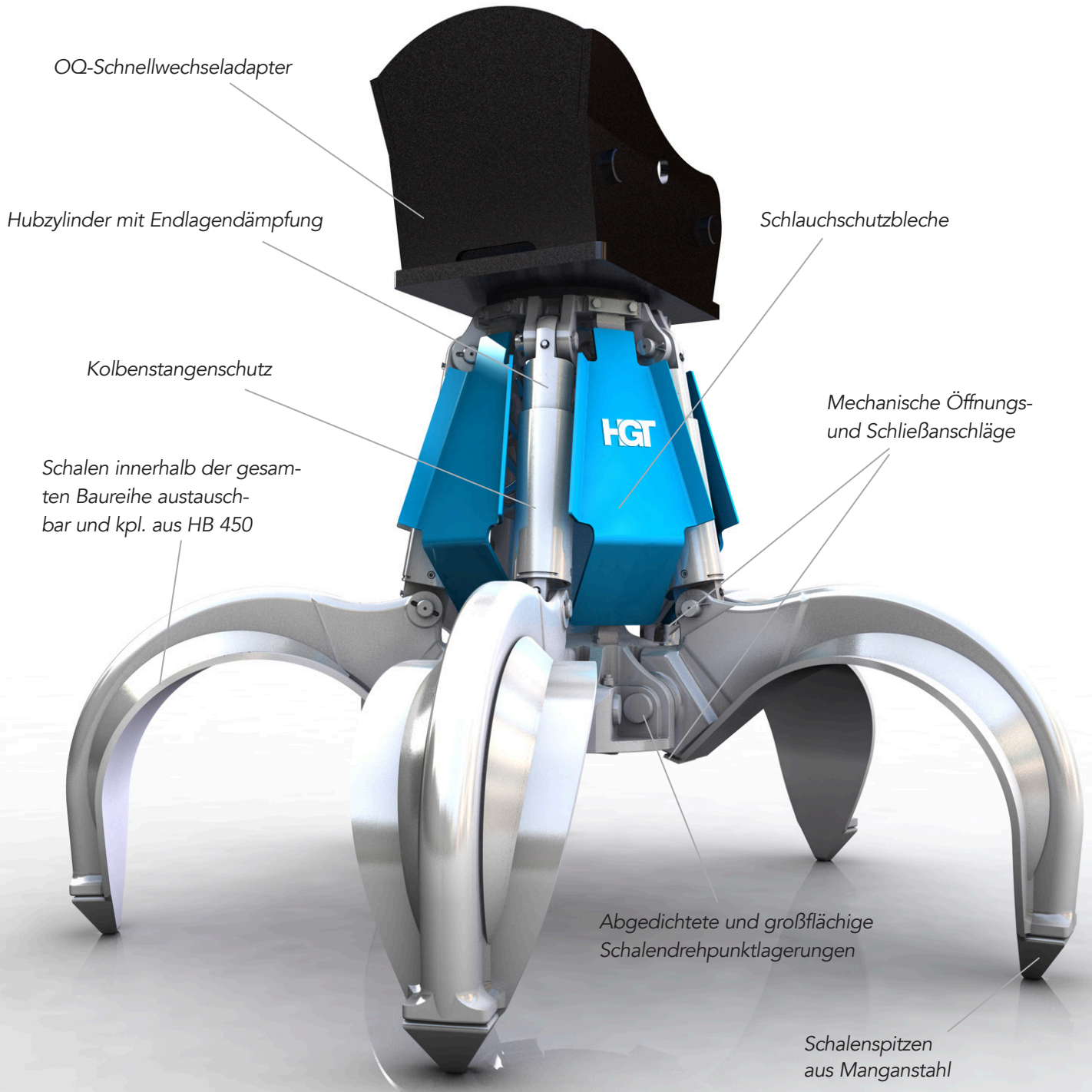

Spezieller Umschlag- und Sortiergreifer für grobes und sperriges Material, wie z. B. in Steinbrüchen, Schrottverwertung, Müll- und Recyclingbetrieben. Als 4- und 5-armige Version lieferbar.