

Baureihe TG, TGR und FTG



Zweischalen-Holz-Verladegreifer

TG5.6

Baggergewichtsklasse (t): 35-80
 Tragfähigkeit (t): Greifer: 12 / Drehwerk: 26
 Betriebsdruck (bar): 350 Greifen / 140 Drehen

Drehzahl (U/min): 10
 Stammlänge (m): 6-10

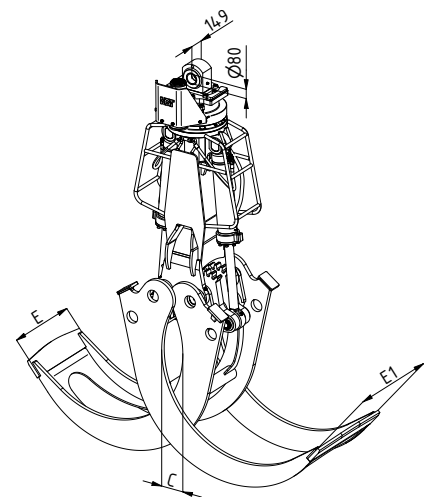
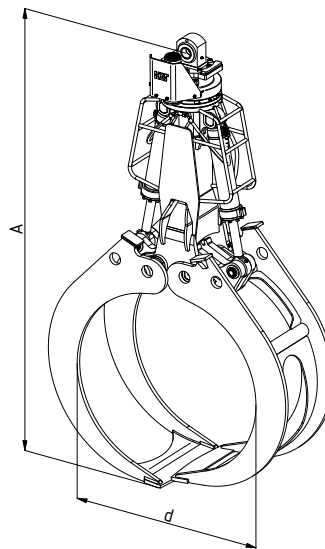
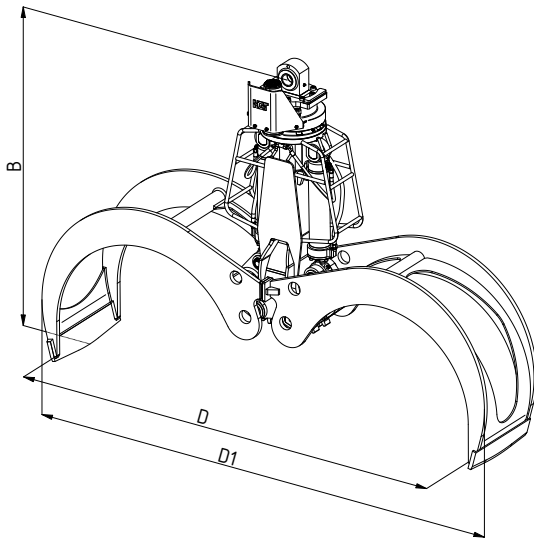

Typ	Inhalt (m ²)	Gewicht (kg)	Abmessungen (mm)					
			A	B	C	d	D/D1	E/E1
TG5.6-1250-B	1,25	2175	3235	2437	100	1265	2815/3045	700/840
TG5.6-1500-B	1,5	2245	3360	2480	115	1378	3045/3305	700/840
TG5.6-1750-B	1,75	2310	3475	2520	130	1472	3278/3546	700/840
TG5.6-2000-B	2,0	2350	3584	2560	150	1617	3483/3748	700/840
TG5.6-2500-B	2,5	2540	3790	2917	175	1783	3860/4150	700/840

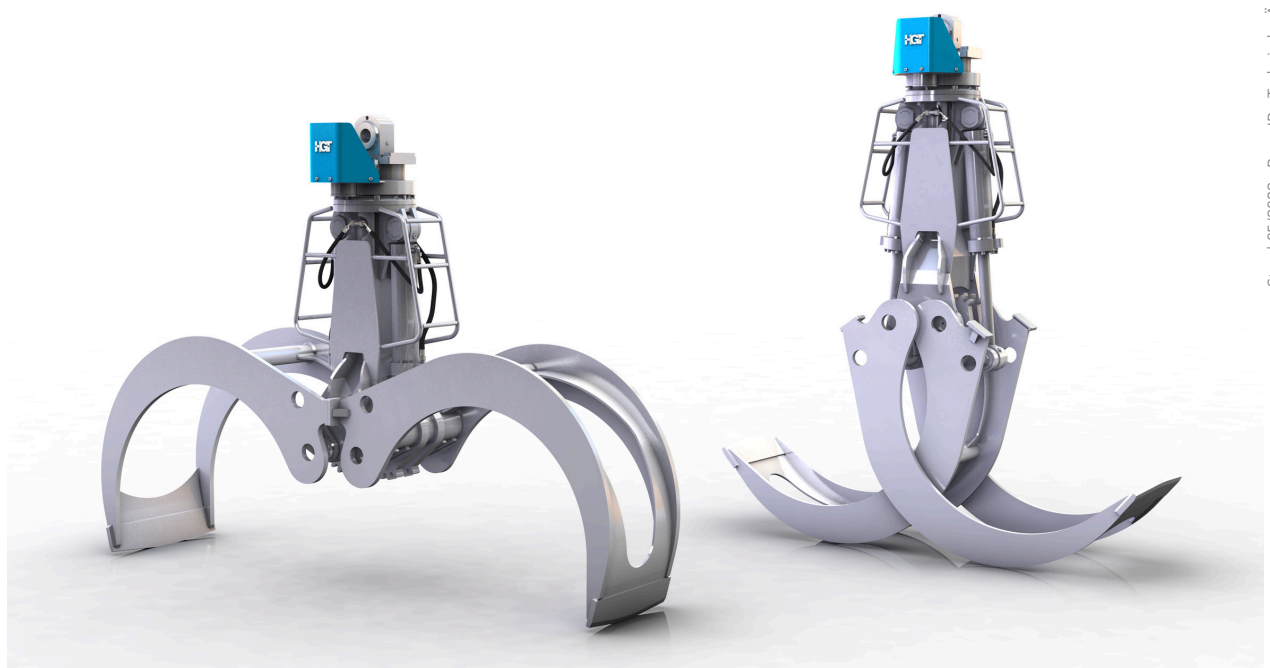

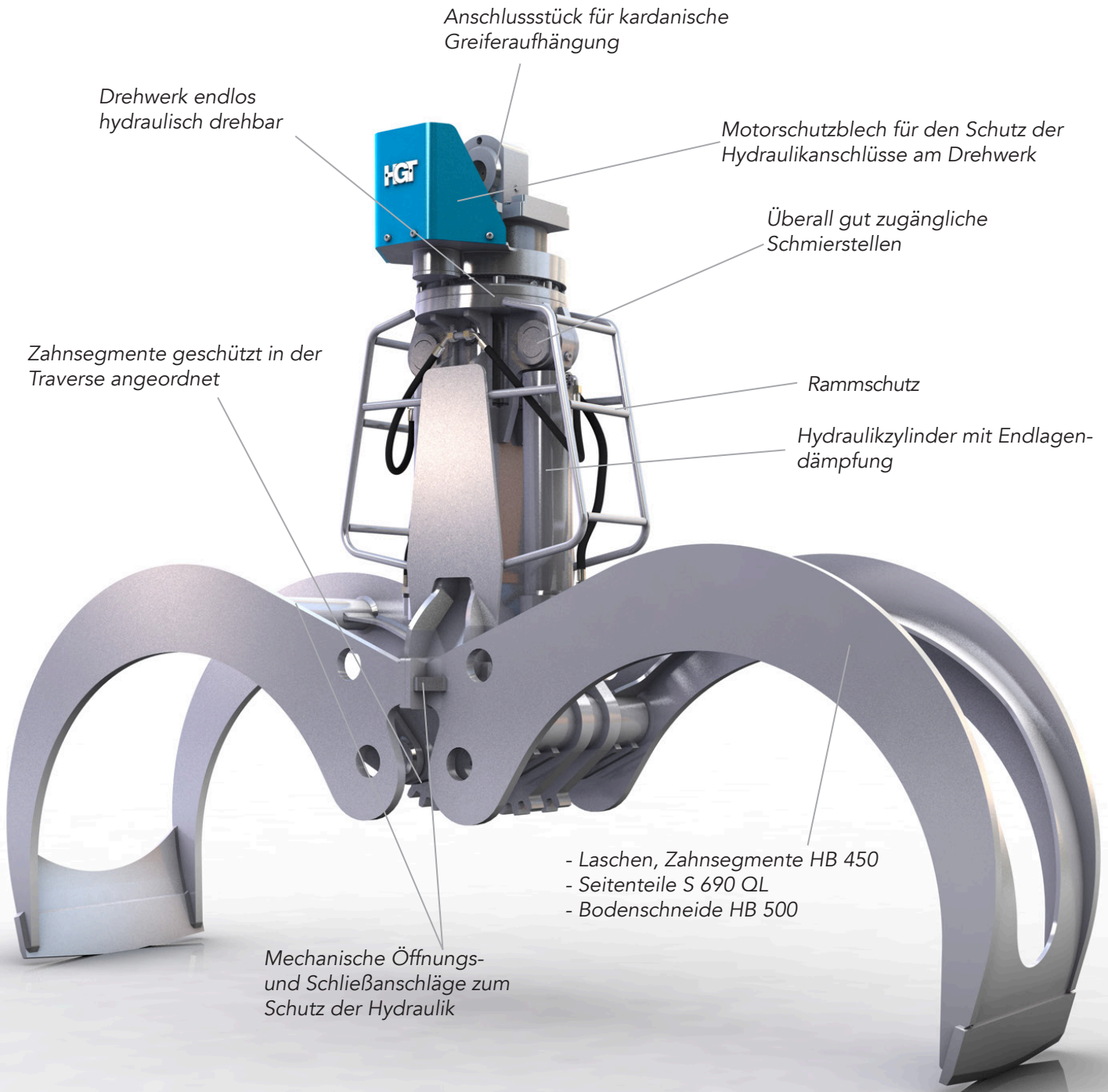

Form W (Wagon)
Claws - outer, vertical

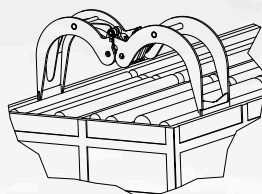

Form B (Box)
Claws - inner, vertical

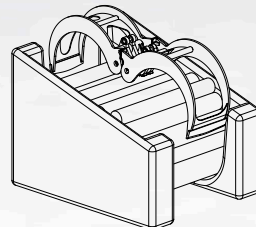

Umschlaggreifer für Stamm- und Rundholz. Aufgrund der Zangenform können die TG-Holzgreifer einzelne sowie mehrere Stämme unterschiedlichster Durchmesser vom Boden, Stapel oder LKW mühelos aufnehmen und sicher halten und handhaben.