

Série DG



Benne preneuse de démolition

DG2

Classe de poids de l'excavateur (t) : 5-9
Contenance (l) : 200

Pression de service (bar) : 300 préhension/250 rotation
Force de serrage (kN) : 36

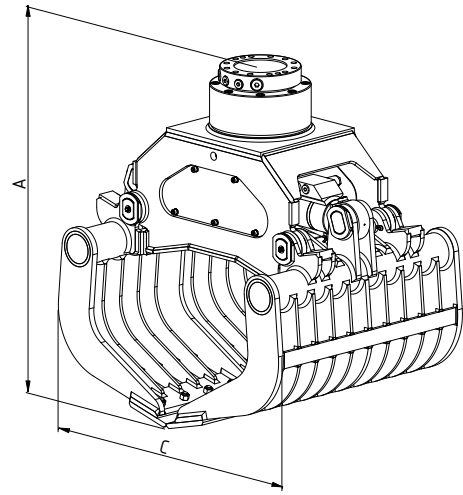
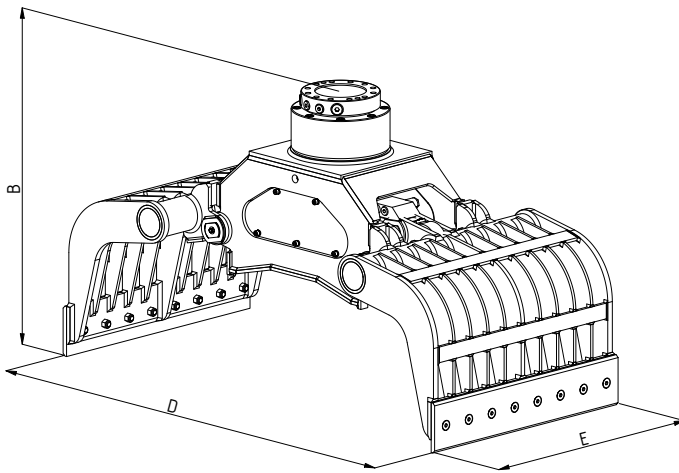

Type	Capacité de charge max. du préhenseur (t)	Capacité de charge max. du mécanisme d'orientation (t)	Poids sans plaque d'adaptation (kg)	Dimensions (mm)				
				A	B	C	D	E
DG2	2	10	508	1080	950	940	1620	600

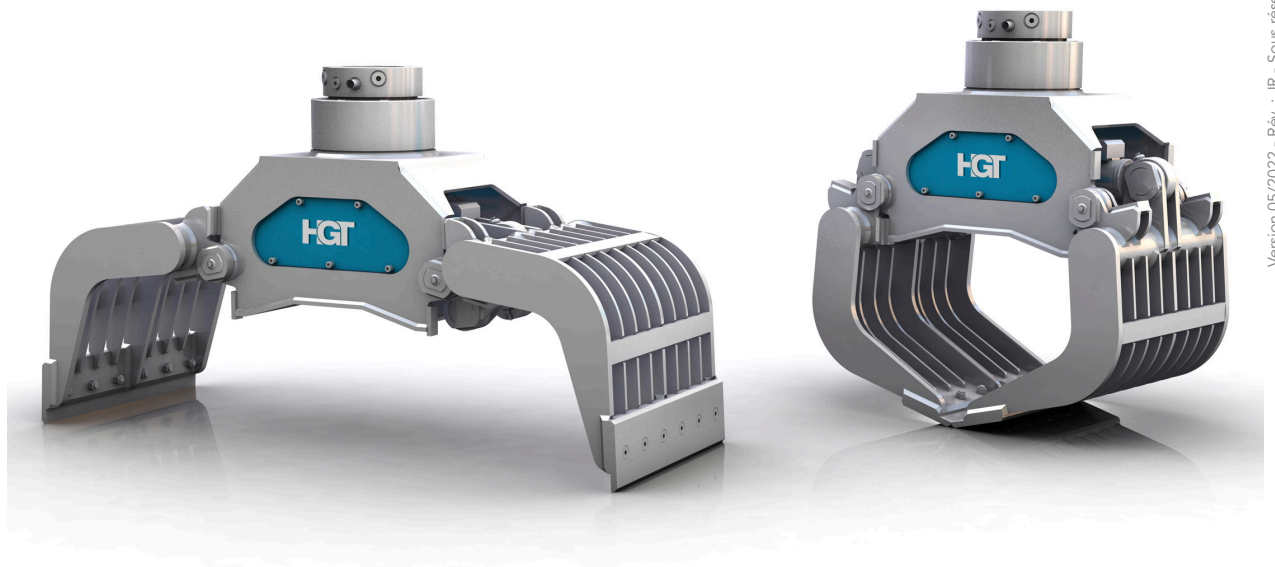

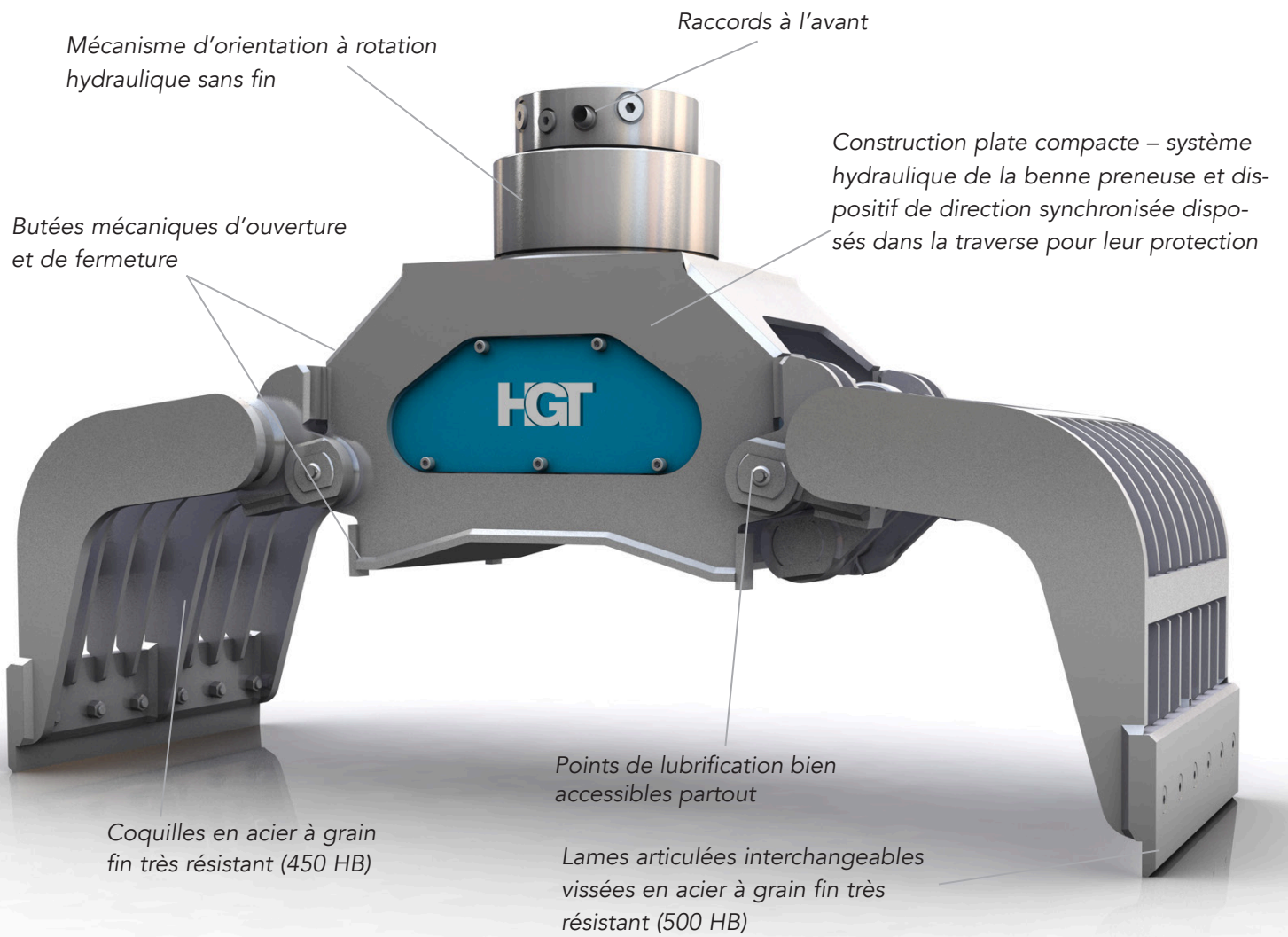

Préhenseur polyvalent pour les applications plus diverses et la manipulation des matériaux les plus variés, telles que la démolition/le tri de gravats, le tri de déchets de construction, le chargement et le tri de matériaux à recycler.