

Série MT



Grappin de chargement à coquilles multiples

MT6.6-5

Classe de poids de l'excavateur (t) : 70-100

Capacité de charge (t) : préhenseur : 15/mécanisme d'orientation : 35

Pression de service (bar) : 350 préhension/140 rotation

Régime (tr/min) : 10

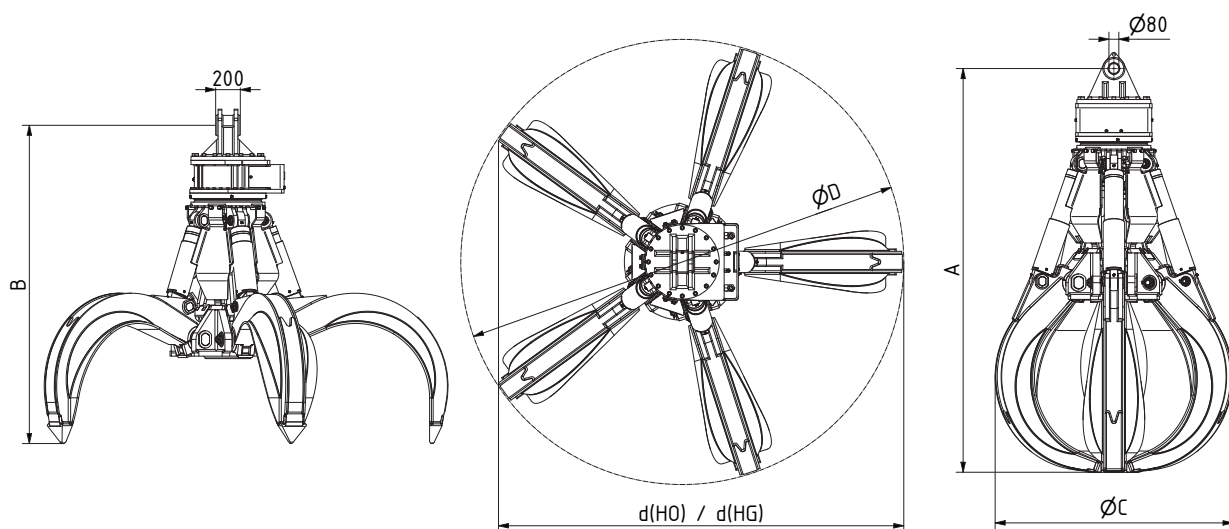

Type	Contenance (l)	Poids (kg)			Dimensions (mm)					
		HO	G	A	B	C	D	d(HO)	d(HG)	
MT6.6-2500-5	2500	4025	4400	3335	2545	2270	3910	3575	3625	
MT6.6-3000-5	3000	4060	4475	3440	2580	2285	4100	3730	3810	
MT6.6-3500-5	3500	4160	4665	3505	2600	2420	4220	3860	3960	



Semi-ouvert (HO) Semi-fermé (HG)



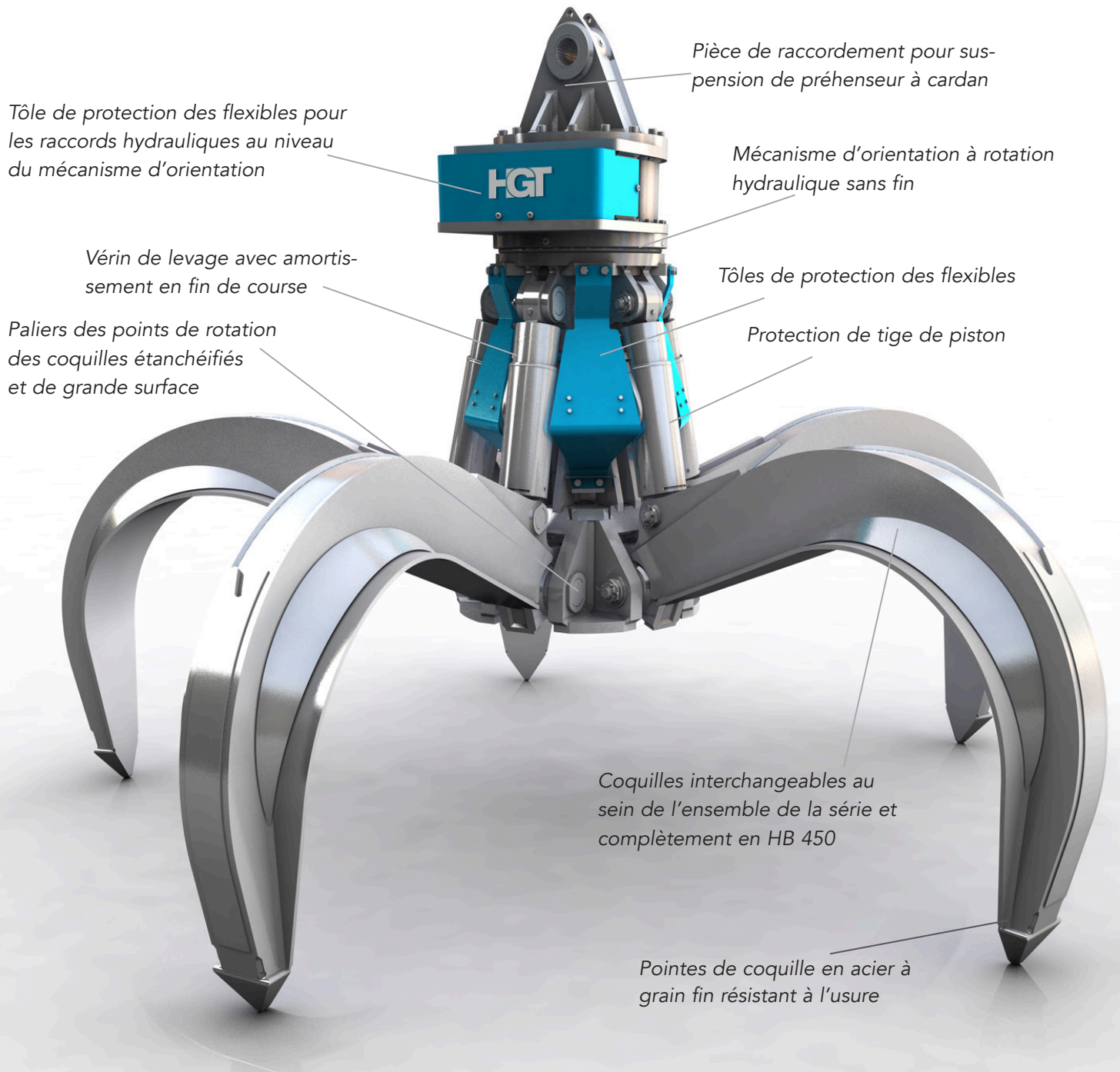

Grappin de manutention et de tri spécial pour les matériaux grossiers et encombrants, tels que dans les carrières, la récupération de ferraille, les entreprises de déchets et de recyclage. Livrable en version à 4 ou 5 bras