

Série OQC



Outils de chargement OQC

OQC-RCS4.6

Classe de poids de l'excavateur (t) : 20-30

Capacité de charge (t) : 4

Pression de service (bar) : 350 préhension

Densité apparente jusqu'à (t/m³) : 2

Force de fermeture maxi. (kN) : 75

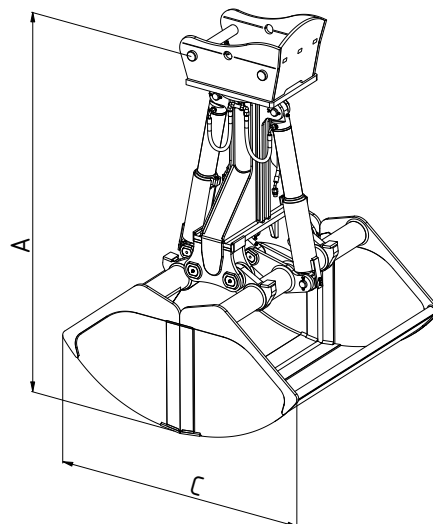
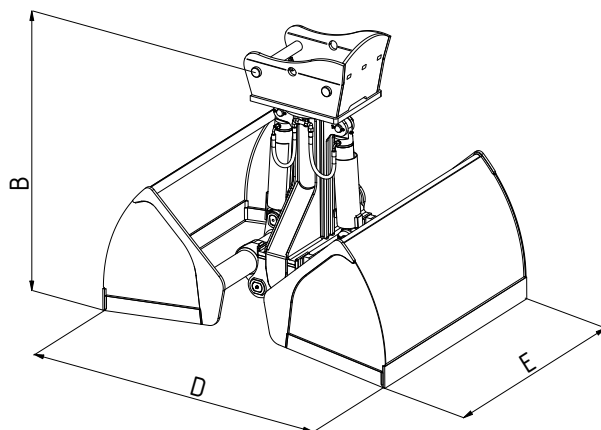

Type	Capacité - SAE (l)	Poids (kg)	Densité apparente jusqu'à t/m ³	Dimensions (mm)				
				A	B	C	D	E
OQC-RCS4.6-1000	1000	1366	2,0	2311	1637	1770	2130	1100
OQC-RCS4.6-1200	1200	1467	2,0	2311	1637	1770	2130	1400
OQC-RCS4.6-1400	1400	1525	2,0	2311	1637	1770	2130	1600
OQC-RCS4.6-1600	1600	1586	1,7	2311	1637	1770	2130	1800



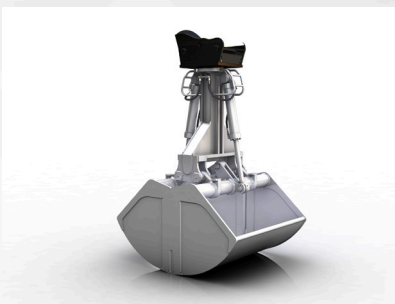
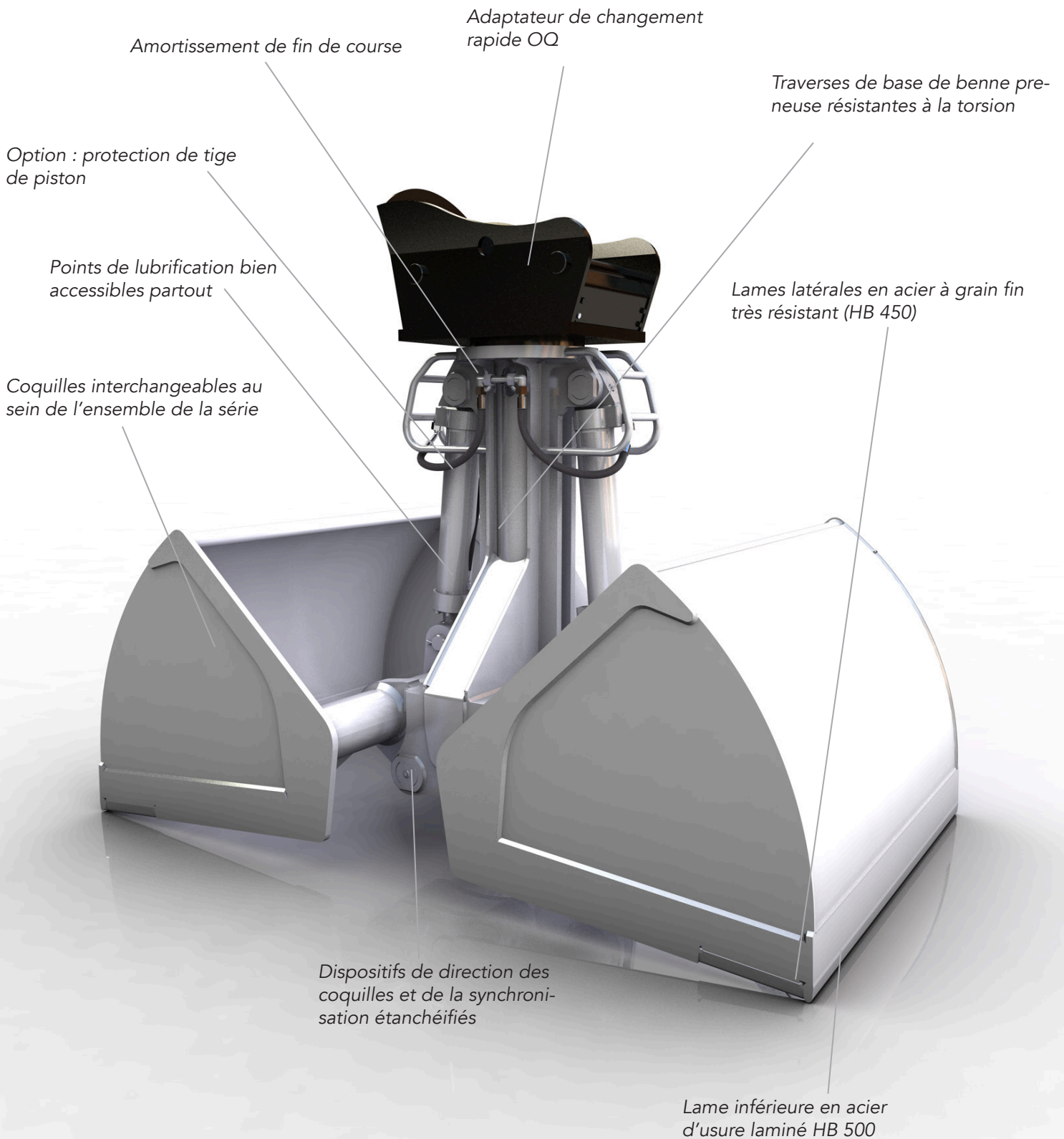

Benne preneuse optimisée pour le transfert du vrac tel que le gravier, le sable, les gravats, les céréales, les aliments, les engrais, les minerais, le charbon, etc.